



## ENERGY EFFICIENT REFRIGERATED AIR DRYERS

*Flexzilla® designs and manufactures products for safe operation. However, operators and maintenance persons are responsible for maintaining safety. All safety precautions are included to provide a guideline for minimizing the possibility of accidents and property damage while equipment is in operation. Keep these instructions for reference.*



**YOU MUST REGISTER TO  
ACTIVATE WARRANTY**



**Scan or go to website hosted below:**

[www.eatoncompressor.com/warranty](http://www.eatoncompressor.com/warranty)

Warranty only valid by following conditions expressed in the Warranty Statement section of this Air Dryer Manual.

## Contents

1. Important Safety Notes - Please read .....	3	5. Technical Specifications .....	12
1.1 Transportation.....	3	6. Diagrams.....	12
1.2 Positioning.....	3	6.1 Air Flow Diagrams.....	12
1.3 Installation .....	3	6.2 Electrical Diagrams .....	14
1.4 Before Operating.....	3	7. ID Diagram Drawings.....	16
1.5 Qualified Service Personnel .....	3	General Arrangements .....	18
1.6 Maintenance By The User .....	4	8. Exploded Diagrams .....	18
2. Introduction To The Dryer.....	4	9. Components Location.....	22
3. Operation .....	4	10. Troubleshooting.....	23
4. Electrical Controller.....	7	11. Check Valve Maintenance.....	26
4.1 Digi-Pro.....	7	12. Warranty .....	27
4.2 ESD 3.....	8		



**YOU MUST REGISTER TO  
ACTIVATE WARRANTY**



**Scan or go to website hosted below:**  
[www.eatoncompressor.com/warranty](http://www.eatoncompressor.com/warranty)

Warranty only valid by following conditions expressed in the Warranty Statement section of this Air Dryer Manual.

## 1. IMPORTANT SAFETY NOTES

When operating the air dryer the operator must apply safe working methods and observe all local safety instructions and relevant regulations.

- A) Prior to installation, the dryer and the compressed air system are to be depressurized and disconnected from the electrical main supply.
- B) The user is responsible for safe operating conditions. Parts and accessories must be replaced if inspection shows that safe operation cannot be assured.
- C) Installation, operation, maintenance and repair are only to be performed by authorized, trained and skilled technicians.
- D) The minimum and maximum values stated must be followed, as well as all of the safety precautions described in this manual.
- E) If any statement in this manual does not comply with the local code laws, the strongest standard is to be applied.

### 1.1. Transportation

- A) Use care and caution when transporting the dryer. Avoid dropping and other physical abuse.
- B) A forklift can be used to transport the dryers provided the forks are long enough to support its full width or length and caution is used throughout the move.

### 1.2. Positioning

- A) The dryer must be installed vertically. A minimum of 20 in. clearance around the dryer is necessary to allow good ventilation and easy access for servicing.
- B) The ambient temperature in the room should not exceed 113°F and should not be below 39.2°F, also taking the heat radiated by the dryer into account.
- C) (40 watt for each liter/sec under ISO 7138-A condition or 18 watts for each SCFM under ISO 7183-B condition).
- D) There should be no chemicals in the atmosphere that will damage the copper source. (Ammonia gas, etc.)

### 1.3 Installation

In addition to the general mechanical construction procedures and local code regulations, the following instructions need to be understood and followed:

- 1) Only authorized, trained and skilled technicians should install the compressed air dryer.
- 2) Safety devices, protecting covers or insulation in the dryers are never to be dismantled or modified. Each pressure vessel or accessory installed outside the dryer with air above atmospheric pressure must be fitted with the required pressure relief safety valves.

### 1.4 Before Operating

The following must be observed before operating the air dryer:

- A) Review all safety precautions.
- B) The dryer connection piping measurements must be selected correctly. (See Technical Specifications)
- C) The dryer connection piping must be adapted to the operating pressure. (See Technical Specifications)
- D) Never operate the dryer at pressure above the maximum specified on the dryer label (See Technical Specifications)
- E) The drains should be opened to atmosphere. If the drains are connected to a pipe/hose, the diameter of the pipe/hose should be large enough to create no back pressure during draining. It is not recommended to reduce the diameter of the pipe/hose less than the port that is given at the drain outlet of the unit. The pipe/hose should be at atmospheric pressure at all time. Back pressure in relevant pipe will result in permanent damage on drain system and function of the filters and/or dryers.

### 1.5 Qualified Service Technicians

- A) Maintenance and repairs should only be performed when the air dryer is shut down, depressurized and when the main power switch is turned off. Lock and tag out of the power supply is recommended.
- B) Only use the appropriate tools for maintenance and repair.
- C) Before dismantling a part under pressure, disconnect the pressure sources and depressurize the system.

 <b>YOU MUST REGISTER TO ACTIVATE WARRANTY</b>		<b>Scan or go to website hosted below:</b> <a href="http://www.eatoncompressor.com/warranty">www.eatoncompressor.com/warranty</a> Warranty only valid by following conditions expressed in the Warranty Statement section of this Air Dryer Manual.
-----------------------------------------------------------------------------------------------------------------------------------	-------------------------------------------------------------------------------------	-----------------------------------------------------------------------------------------------------------------------------------------------------------------------------------------------------------------------------------------------------------

- D) Proceed carefully during maintenance and repair. Prevent dirt from entering by covering parts and orifices with a clean cloth, paper or tape. A receiver should never be welded or modified in any way.
- E) Never leave tools, loose parts or cleaning rags in or on the air dryer.
- F) Before putting the dryer into service, check the settings of the control and safety devices as well as the pressure and temperature of the compressed air circuit.

### 1.6 Maintenance By The User

- A) Keep the dryer clean.
- B) Regularly check the correct operation of the condensate drain water trap.
- C) Ever six months, check and clean the drain strainer by undoing the access screw and rinsing the filter with tap water to remove the trapped dirt from the inside.
- D) For air cooled dryers, clean the air condenser as soon as it's dirty or clogged.
- E) For optional water-cooled condensers, use only clean water and install a water filter if needed. Use proper water treatment if calcium levels are high.
- F) Check the trouble-shooting list in case of maintenance problems.
- G) Check operating pressures, temperatures and time settings after maintenance. If operating and safety devices function properly, the air dryer may be used.

## 2. INTRODUCTION TO THE DRYER

### A) Purpose of this dryer

- 1) This refrigerated compressed air dryer has been designed to remove water vapor from the industrial compressed air system.
- 2) This dryer has been designed for indoor operation.
- 3) The minimum and maximum values stated must be observed, as well as the safety precautions described in this manual.

### B) Dryer label

The following label is affixed on the cabinet of the refrigerant compressed air dryer.

REFRIGERATED AIR DRYER			
MODEL #	<input type="text"/>	CFM	<input type="text"/>
		SERIAL #	<input type="text"/>
Max Refrigerant Pressure	<input type="text"/>	Voltage	<input type="text"/>
Max Air Pressure	<input type="text"/>	IP Rating	<input type="text"/>
Max Air Inlet Temp	<input type="text"/>	Refrigerant	134 a <input type="text"/>
Min Ambient Temp	<input type="text"/>	Weight	<input type="text"/>
Max Ambient Temp	<input type="text"/>	Fan	<input type="text"/>
Min Circuit Ampacity	<input type="text"/>	Compressor	<input type="text"/>
Max Protective Device Rating	<input type="text"/>	Largest Motor	<input type="text"/>

FOR SALES, SERVICE, PARTS OR TECHNICAL SUPPORT CALL US TOLL FREE AT 877-283-7634

#### Dryer Label Descriptions:

<b>Model #:</b>	Dryer Model No.
<b>CFM:</b>	Cubic feet per minute
<b>Serial #:</b>	Dryer Serial No.
<b>Max. Refrigerant Pressure:</b>	Dryer maximum working pressure
<b>Max. Air Pressure:</b>	Maximum air pressure
<b>Max. Air Inlet Temp.:</b>	Maximum air inlet temperature
<b>Min. Ambient Temp.:</b>	Minimum ambient temperature
<b>Max. Ambient Temp.:</b>	Maximum ambient temperature
<b>Min. Circuit Ampacity:</b>	Minimum circuit ampacity
<b>Max. Protective Device Rating:</b>	Maximum protective device rating
<b>Voltage:</b>	Main supply voltage
<b>IP Rating:</b>	Protection rating
<b>Refrigerant 134a:</b>	Amount of refrigerant gas used
<b>Weight:</b>	Dryer weight
<b>Fan:</b>	Model of fan used
<b>Compressor:</b>	Model of compressor used
<b>Largest Motor:</b>	Model of dryer motor used

### C) Working details

#### 1) Refrigerant circuit:

The refrigerant circuit can be divided into 3 parts:

- A) Low pressure section with an evaporator (heat exchanger)
- B) High-pressure section including: Condenser, liquid receiver (if installed) and the filter dryer.
- C) Control circuit including: compressor, expansion valve, by-pass valve (if installed), fan pressure switch (if installed)

#### 2) The refrigerant circuit operates as follows:

- A) The compressor compresses gaseous refrigerant to a high temperature.
- B) The hot refrigerant condenses in the condenser. Being liquefied it is stored in the liquid receiver (if installed).
- C) The liquid is taken out of the storage vessel and

	<p><b>YOU MUST REGISTER TO ACTIVATE WARRANTY</b></p>		<p><b>Scan or go to website hosted below:</b>  <a href="http://www.eatoncompressor.com/warranty">www.eatoncompressor.com/warranty</a>                      Warranty only valid by following conditions expressed in the Warranty Statement section of this Air Dryer Manual.</p>
-------------------------------------------------------------------------------------	------------------------------------------------------	-------------------------------------------------------------------------------------	------------------------------------------------------------------------------------------------------------------------------------------------------------------------------------------------------------------------------------------------------------------------------------------

injected in the evaporator (heat exchanger) by an expansion valve. This expansion valve is protected by a filter, which removes particles and humidity that could be in the circuit.

- D) The injected liquid fills in the refrigerant section of the air/refrigerant heat exchanger and evaporates by taking out the humidity from the compressed air. The gaseous refrigerant is sucked in the compressor and the cycle carries on.
- E) In order to keep the evaporation pressure steady, and the refrigerant temperature in the heat exchanger, a by-pass valve is injecting hot gaseous refrigerant in the circuit. On certain dryers, an automatic expansion valve regulates the amount of refrigerant.

**3) Compressed air circuit**

- A) The saturated hot compressed air flows into the economizer where it is pre-cooled by the out flowing dry chilled air. In the cold operating conditions the air refrigerant section continues to cool down to dew point and enters the separator where condensates are collected. The outgoing chilled air is then warmed up in the economizer by the hot incoming air. This eliminates condensation on dryer outlet air piping.
- B) The condensates are collected after centrifugal separation and drained out through the automatic trap.
- C) As long as the compressed air temperature does not drop below dew point, there will be no condensation in the air circuit.

**Compressed Air Dryer Working Principle**

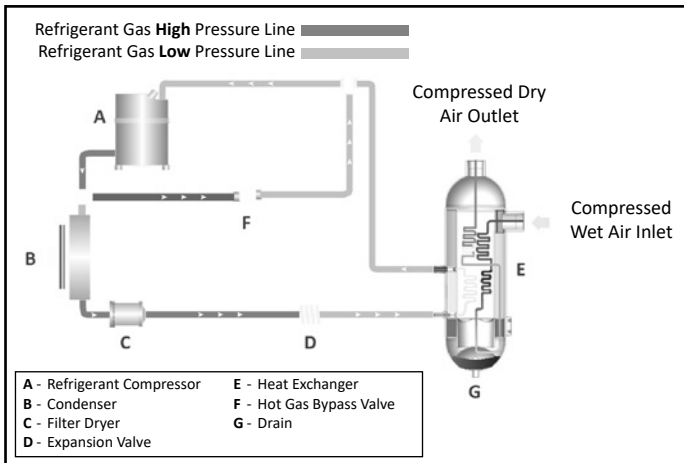

**4) Refrigerant compressor**

Increases the pressure of temperature of refrigerant. There are two types of compressors commonly used according to refrigerant capacity on this application:

- Piston type
- Scroll type

**5) Condenser**

Dissipates the heat provided by evaporator and compressor. there are two types of condensers used on the application:

- Air Cooled Type (standard)

These condensers are designed to dissipate the heat to the ambient air. The fans are used to force the air flow through the cooling fins to enhance the heat transfer.

- Water Cooled Type (optional)

These condensers are designed to dissipate the heat to a water flow. A shell and tube heat exchanger is used for this purpose.

**6) Refrigerant circuit protection**

- A) Overload: The single phase refrigerant compressors are equipped with an overload switch in case of malfunction, if overload switches automatically.
- B) High Pressure Safety Overload Switch: Refrigerant line is considered a pressure vessel. That is why it is protected against bursts by the help of manually resetting the switch. It is set to 362 psi for dryers working with R134a refrigerant.
- C) Filter dryer: A refrigerant circuit is a close circuit and total water removal in the refrigerant circuit is necessary in order to obtain correct operation.
- D) To avoid problems, the refrigerant circuit must be vacuumed before loading the refrigerant.
- E) Water-cooled dryers have a safety high-pressure switch. In case of cooling water failure, the safety switch stops the dryer. When the safety switch has tripped out, it has to be manually resettled before switching on the dryer.

**7) Refrigerant circuit controls**

- A) Liquid refrigerant injection: the liquid refrigerant is released into the evaporator by a control valve. This is a thermostatic valve for maintaining a constant overheating of the refrigerant in the evaporator(s).
- B) Constant evaporating pressure: In the dryers equipped with a by-pass valve, the evaporating pressure is kept constant by a controlled injection of hot gas from the high-pressure side into the low-pressure section of the circuit.



**YOU MUST REGISTER TO ACTIVATE WARRANTY**



**Scan or go to website hosted below:**  
[www.eatoncompressor.com/warranty](http://www.eatoncompressor.com/warranty)  
 Warranty only valid by following conditions expressed in the Warranty Statement section of this Air Dryer Manual.

### 8) Condensate drain-trap assembly

Dismantling the drain is easy because it can be isolated from the air circuit under pressure with a ball valve. The drain has to be depressurized before being dismantled.

### 9) Heat exchanger modular design

A) The dryers are equipped with a compact

This assembly has been specially designed to dry compressed air and is made of:

- 1) An economizer which pre-cools the entering hot air with the out flowing cold air.
- 2) Air/refrigerant exchanger is cooling down the compressed air.
- 3) A centrifugal separator concentrating all condensates and requiring no maintenance.

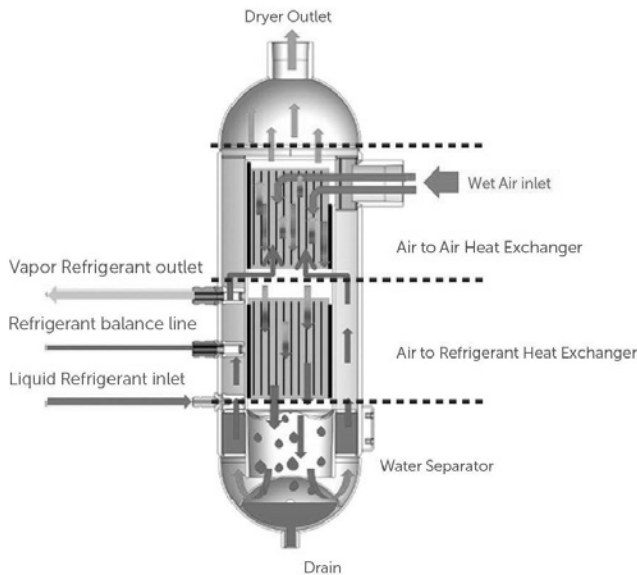

### 10) Accessories

Temperature switch: Located inside the dryer, this temperature switch is adjustable from 32°F up to 95°F.

Digital Controller – DigiPro: This device helps dryer save energy when there is not any compressed air flow in the dryer. This information can be reached: Dew point value, periodic maintenance interval display, status report, run time meter, temperature unit selection (°F or °C)

Digital Controller – ESD3: Energy Saving Device: (ESD) This device helps dryer save energy when there is not any compressed air flow in the dryer. This information can be reached: Dew point value, periodic maintenance interval display, status report, run time meter, temperature unit selection (°F or °C)

## 3. OPERATION

Control panels for FDRCF Series

The control panel of the dryer includes the following elements:

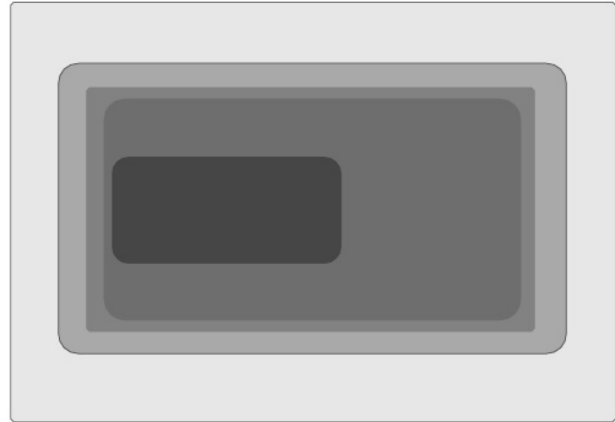

Single Phase	Digital Controller
FDRCF1150030 / FDRCF1150058	Digi-Pro



### IMPORTANT NOTES

The Dryer has two Compressed Air Filters inside. It is better to change filter element for the best efficiency when the alarm status is active.

It is recommended to keep replacement filter elements in your stock in order to replace them when needed.

FDRCF range dryers have low pressure drop according its competitors.

Do not use FDRCF range dryers together with other dryers which have higher pressure drop without getting the confirmation from our technical team.



Scan or go to website hosted below:

[www.eatoncompressor.com/warranty](http://www.eatoncompressor.com/warranty)

Warranty only valid by following conditions expressed in the Warranty Statement section of this Air Dryer Manual.

### 3.1. During Operation

Regularly check the digital temperature controller ESD3 or Digi-Pro on dryer.

### 3.2 Start up and shut-down

Warning: Avoid leaving the dryer off when compressed air is still flowing through it.

### 3.3 Starting for the first time or after a long stop

- 1) Set the rotary switch to “I” This preheats the dryer and turns the drain system on. It is recommended to leave the dryer power on permanently so the crankcase heater runs continuously.



#### IMPORTANT NOTE

- 2) After a long stop of the dryer it is MANDATORY to allow a preheating period of minimum 4 hours before starting again, to avoid any compressed air flow during preheating.

- 3) Follow the daily starting and shut down procedure.

### 3.4 Daily starting and shut-down

- A) Push on the ON button to start the dryer.
- B) The start light or Dryer Active will indicate that the dryer is running.
- C) To stop the dryer, first stop the airflow (either shut-down the air compressor or close the inlet/outlet or by-pass valve) When the air flow is stopped, set the rotary switch on “0” Set it again on “I” in order to keep the preheating on.



#### IMPORTANT NOTE

- 4) Avoid leaving the dryer stopped when compressed air is still flowing through it.
- 5) To switch the already preheated dryer on again, simply push the green start button.

## 4) ELECTRICAL CONTROLLER

### 4.1 DIGI-PRO

#### 4.1.1 Description

With the Digi-Pro series controllers, air dryers have outstanding technology for both functionality and performance, as well as appearance. The multi-functional display provides an accurate digital dew point display as well as coded alarm monitoring of the refrigerant dryer.

#### DIGITAL CONTROLLER ADVANTAGES

- Digital dew point monitoring
- Energy-saving mode display
- Periodic maintenance interval display
- Status report
- Run time meter
- Fahrenheit and Celsius selection

#### 4.1.2 Operation

Using the Digi Pro controller as shown in the picture below:



#### 4.1.3 Menu Buttons

 **PROGRAM**

To modify the parameter, press and release button set. The menu is used by service tech. To disable the Key Lock: Press and hold the SET for 4 seconds.

 **POWER**

This button is used for starting and stopping the dryer. Press and hold for 4 seconds to start or stop.

 **MENU**

These buttons are used to navigate between screens and adjust values.

 **MANUAL DRAIN**

This button is used for manual control of the drain output. Press and hold for 4 seconds to drain manually.



Scan or go to website hosted below:

[www.eatoncompressor.com/warranty](http://www.eatoncompressor.com/warranty)

Warranty only valid by following conditions expressed in the Warranty Statement section of this Air Dryer Manual.

### 4.1.4 ALARM DISPLAY



Alarms / warnings are displayed on the digital screen. That means the dryer is not working under normal operating conditions, which are outside the range of set values.

Please contact service when an alarm/warning occurs.

Alarm Code	Alarm Description	Reason for Alarm
tAL	Low Temperature Alarm	Refrigerant line temperature is lower than specified set values.
tAH	High Temperature Alarm	Refrigerant line temperature is higher than specified set values.
FIL	Filter Change Alarm	Filter element needs to be replaced.
SEr	General Service Alarm	General service time of the dryer.
HP	High Pressure Alarm	Refrigerant high line pressure is higher than specified set values.
Pr1	Temperature Probe Alarm	Temperature sensor is faulty.
tSH	High Suction Line Temp	Temperature of refrigerant suction line is higher than specified set values.

### 4.1.5 MODE DISPLAY



**DRYER ACTIVE MODE**

This mark indicates that the dryer is performed in active state and drying.



**AUTOMATIC DRAIN MODE**

Shows if the drain system is activated.



**ENERGY SAVING MODE**

Shows if the energy saving mode is activated.



**CELSIUS UNIT MODE**

Indicates that Celsius temperature unit is selected.



**FAHRENHEIT UNIT MODE**

Indicates that Fahrenheit temperature unit is selected.



**COMPRESSOR STANDBY MODE**

This mode shows that the dryer is ready for drying operation.



**SERVICE MODE**

This mode shows that the dryer is in the service time.

## 4.2 ESD 3

### 4.2.1 DESCRIPTION

E-687 is designed as a controller for refrigerant type compressed air dryers. The controller has 8 temperature sensor inputs.

The controller has an RS-485 communication interface that can be used for remotely monitoring channel temperatures, set points, input and output status.

Modbus RTU protocol is used for communication.

The front panel of the controller contains a four line 20 character LCD display and buttons that are used in configuration and manual control operations.

The dimensions of the controller are 3.7 x 7.5 in. (front panel) with a depth of 4.3 in..

The panel cutout should be 3.5 x 7.2 in..

The operating voltage of the controller is 20 - 60V AC or 20 - 85V DC.

### 4.2.2 OPERATION

The front panel view of E-687 controller is shown in the below figure. The front panel of the controller contains a four line 20 character LCD display, 10 buttons and 2 indicator LEDs.

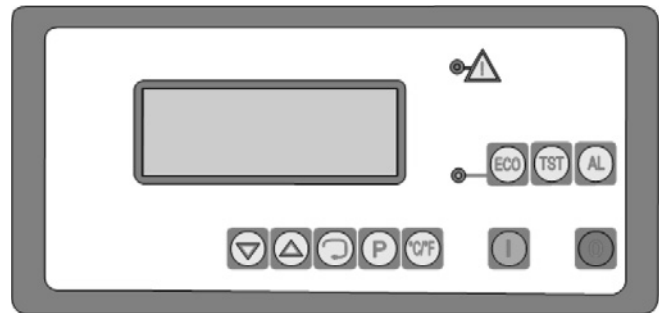

The Front Panel View of E-687 Controller

**ECO** button is used to enable or disable the ECO (economy) mode. Pressing this button complements the state of ECO, i.e. if it is enabled; disables, if it is disabled; enables the ECO mode. The green LED on the left side of the **ECO** button lights if the ECO mode is enabled.

**TST** button is used for manual control of the drain output.

**AL** button is used for alarm acknowledge. The dryer is automatically stopped if a fault is detected. In that



Scan or go to website hosted below:

[www.eatoncompressor.com/warranty](http://www.eatoncompressor.com/warranty)

Warranty only valid by following conditions expressed in the Warranty Statement section of this Air Dryer Manual.



case, the alarm output and the alarm indicator LED (red) on the front panel become activated. In order to restart the dryer, alarm should be acknowledged and “restart delay” period should be timed out. Pressing button acknowledges the alarm and reenergizes the alarm output and alarm LED.

The buttons below the LCD display (▼, ▲, ⌂ and P) are used in screen selection and configuration operations.

⊕ button is used to change the temperature unit from °C to °F or vice versa.

⏪ and ⏩ buttons are used for starting and stopping the dryer. If the dryer is stopped manually, it cannot be started before “restart delay” period is timed out.

⊕, ⊖, ⊞, ⊚, ⊛ and ⊜ buttons are disabled during configuration operations.

### 4.2.3 OPERATION SCREENS

#### 4.2.3.1 The Normal Operation Screen

When the controller is powered on, it displays the type and a message, and then the restart delay timer is set to 5 seconds. After 5 seconds, the normal operation screen is displayed as shown in below figure:

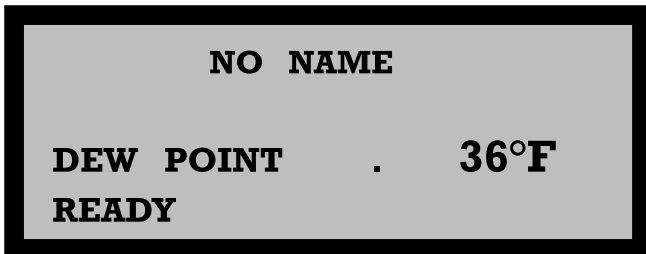

The exchanger temperature (Dew Point) and operation state of the dryer is displayed in this screen. If there is a situation which will prevent the operation of the dryer then the “READY” message in the last line will become “DISABLED”. See below figure:

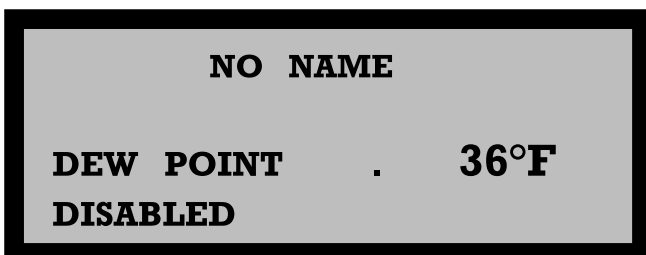

**In order to start the dryer, the following conditions must be satisfied.**

1. All the temperatures except the exchanger temperature and condenser outlet temperature must be between their low and high limits. The low pressure line temperature can be ‘HIGH’.
2. Digital Input 3 (Compressor Fault) is not activated.
3. Digital Input 4 (Compressor Overload) is not activated.
4. Digital Input 5 (Fan Fault) is not activated.
5. Digital Input 6 (Fan Overload) is not activated.
6. Digital Input 7 (Phase Sequence Error) is not activated.
7. Digital Input 8 (Remote Disable) is not activated.
8. Digital Input 11 (High Pressure) is not activated.
9. Digital Input 12 (Low Pressure) is not activated.

If all the above conditions are checked, the message in the last line of the normal operation screen will be “READY” and the dryer can be started either pressing button on the front panel or activating Digital Input 1 (Remote Start) or activating Digital Input 13 (Remote Control). When the dryer is started, the normal operation screen is displayed as shown in below figure:

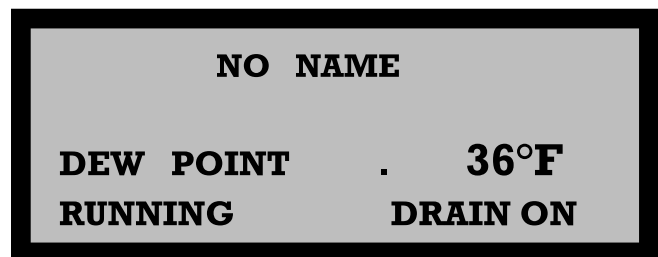

In the beginning, Digital Output 1 (Compressor Motor), Digital Output 2 (Drain Output) and Digital Output 3 (Dryer is Running) become active. While in normal operation, the drain output is controlled according to the configured “drain on” and “drain off” periods. “DRAIN ON” message is displayed in the end of the last line while the drain output is active.

When the Digital Input 9 (Fan Motor is on) is activated, “FAN MOTOR IS ON” message is displayed in the second line as shown in below figure:

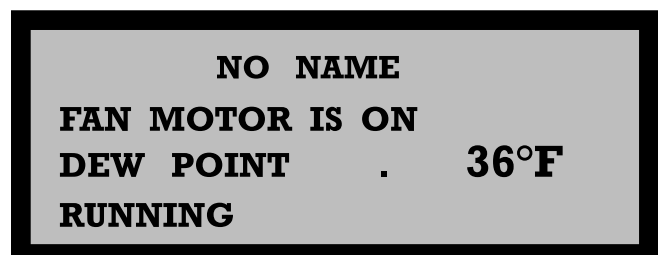



**YOU MUST REGISTER TO ACTIVATE WARRANTY**



**Scan or go to website hosted below:**  
[www.eatoncompressor.com/warranty](http://www.eatoncompressor.com/warranty)  
Warranty only valid by following conditions expressed in the Warranty Statement section of this Air Dryer Manual.

Digital Input 14 (Water Pump is on) activates “WATER PUMP IS ON” message as shown in below figure:

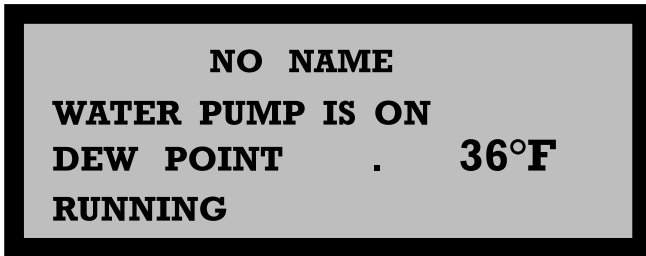

When ECO mode is enabled and the exchanger temperature is less than or equal to “ECO Start Set point” and this condition is prevailed more than “ECO Start Delay”, then, the compressor motor is stopped and ECO operation starts. During the ECO operation the appearance of the display is given in below figure. The value at the end of the second row indicates the time in seconds since beginning of the ECO operation.

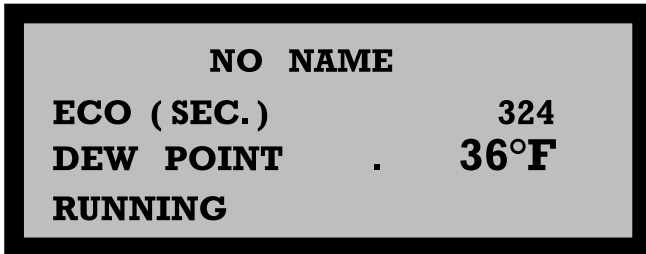

Pressing and keys simultaneously at this page toggles the controller between automatic and manual mode. In manual mode, the dryer starts and stops manually by using and buttons. Unlike the manual mode, automatic mode enables the controller to start and stop automatically at pre-programmed times on a daily basis.

When running in automatic mode, current scheduling information messages are also activated in the second line of the displays as show in below figure. “NOT SCHEDULED” message is displayed when no schedule exists. “START IN XXX” shows the time to the next scheduled program in minutes and “STOP IN XXX” message shows the time to the end of current running program in minutes.

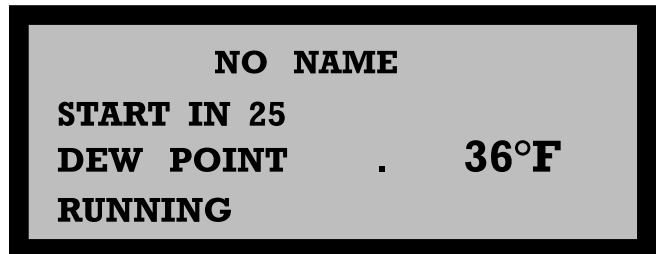
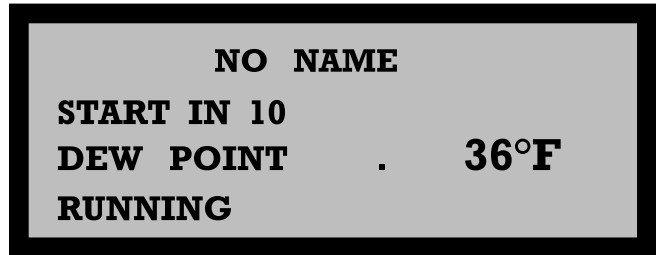
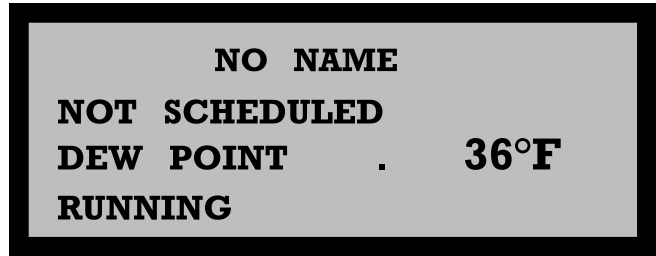

If the dryer is stopped manually by using button, or activating Digital Input 2 (Remote Stop) or deactivating Digital Input 13 (Remote Control), the normal operating screen is displayed as shown in below figure. The number at the end of the last line indicates the remaining time in seconds from the restart delay. If this number becomes zero and there is no anomaly, the dryer can be restarted.

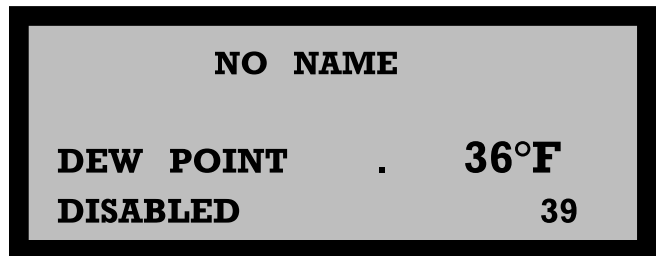

The first line in the normal operation screen (NO NAME) is user configurable.

If the exchanger temperature sensor is broken, dew point temperature will be displayed as 1000°C.









**YOU MUST REGISTER TO ACTIVATE WARRANTY**



**Scan or go to website hosted below:**  
[www.eatoncompressor.com/warranty](http://www.eatoncompressor.com/warranty)  
Warranty only valid by following conditions expressed in the Warranty Statement section of this Air Dryer Manual.

### 4.2.4 The Info Screens

Various data related to the dryer can be monitored by sequentially pressing  button. Pressing  button, changes the display screen. While one screen is displayed, pressing  button reverts to the normal operation screen. The flow chart for monitoring the dryer data is given in figure on right. In this figure, screen numbers are shown on the upper left of the screens. Screen 1 is the normal operation screen. While this screen is displayed, pressing  button selects Screen 2. By successively pressing  button, all the screens can be accessed. Screens can also be selected by  and  buttons.

In Screen 2, Screen 3 and Screen 4, the sensor temperatures are displayed. If the measured temperatures are between their low and high limits, only the temperature value is displayed, otherwise “LOW” or “HIGH” message is added in the end of the line. In case of sensor break, only “SENSOR BREAK” message is displayed.

In Screen 5 and 6 the states of the compressor motor, fan motor, the phase sequence, remote disable and air pressure are displayed. This data is derived from the digital inputs.

The message in the first line of Screen 5 is determined by Digital Input 3 and Digital Input 4 (Compressor Fault and Compressor Overload). The figure on right shows the relation between digital inputs and the message.

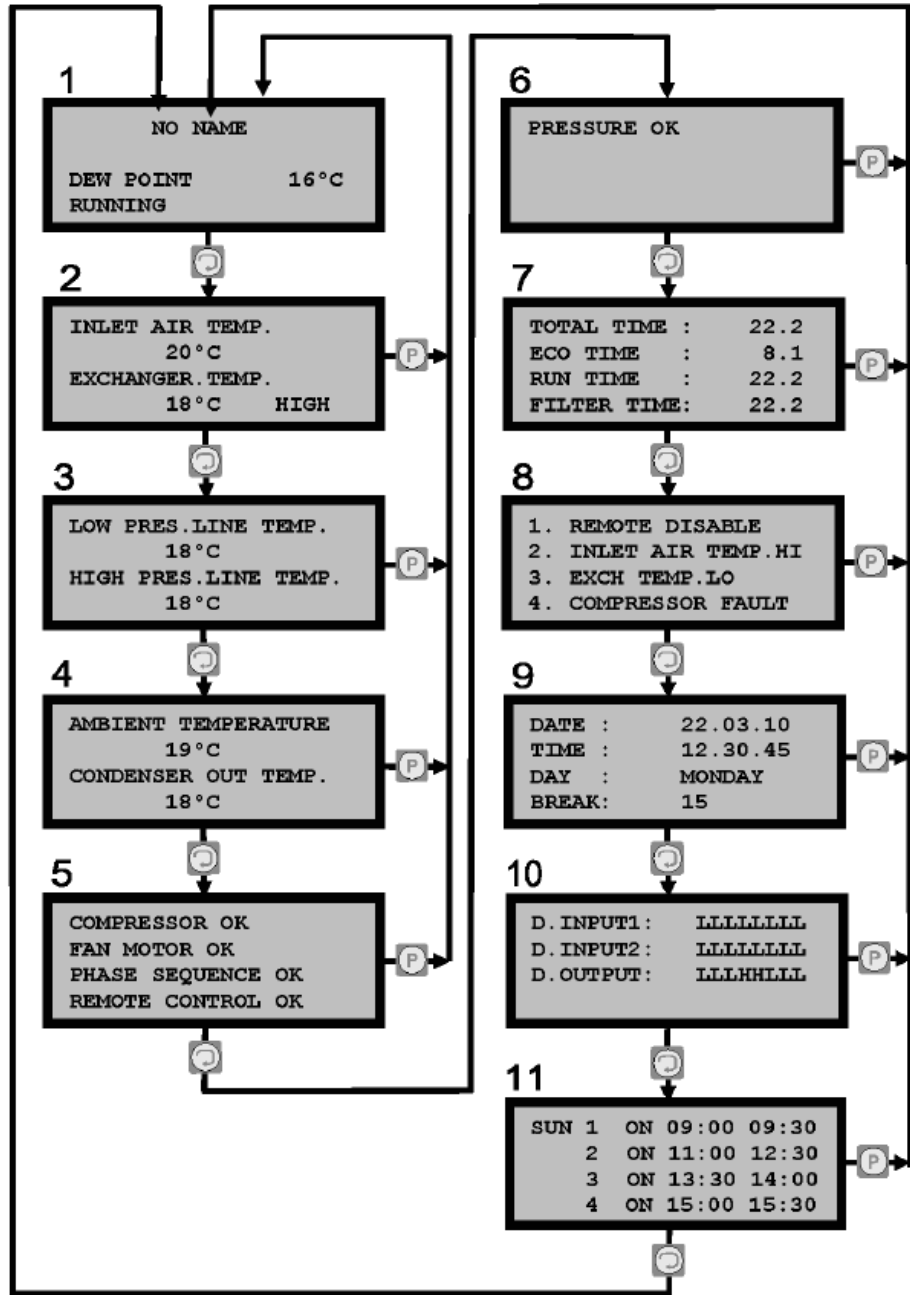



**YOU MUST REGISTER TO ACTIVATE WARRANTY**



**Scan or go to website hosted below:**  
[www.eatoncompressor.com/warranty](http://www.eatoncompressor.com/warranty)  
 Warranty only valid by following conditions expressed in the Warranty Statement section of this Air Dryer Manual.

Screen 8 displays the last four events that caused the dryer stopping automatically. The possible alternatives for these messages are given below.

INLET AIR TEMP.LO	COMPRESSOR FAULT
INLET AIR TEMP.HI	COMP.OVERLOAD FAN
EXCH.TEMP.LO	MOTOR FAULT FAN
EXCH.TEMP.HI	MOT.OVERLOAD PHASE
LO.PRES.L.TEMP.LO	SEQ.ERROR REMOTE
LO.PRES.L.TEMP.HI	DISABLE PRESSURE
HI.PRES.L.TEMP.LO	HIGH PRESSURE LOW
HI.PRES.L.TEMP.HI	CONDENSER FAULT
AMB.TEMP.LO	
AMB.TEMP.HI	

Screen 9 displays the date and time.

Screen 10 displays the states of the digital inputs and digital outputs. The letters 'L' and 'H' stands for 'not activated' and 'activated' states respectively.

The data in the first line of Screen 10 (D.INPUT1), from right to left corresponds to Digital Input 1 to 8.

The data in the second line of Screen 10 (D.INPUT2), from right to left corresponds to Digital Input 9 to 16.

The data in the third line of Screen 10 (D.OUTPUT), from right to left corresponds to Digital Output 1 to 8.

Screen 11 displays automatic mode scheduling for the day. Please see Section 2.3.3 for scheduling for auto/manual selection.

### 4.3.4 Operation Principles

In order to start the dryer, the following conditions must be satisfied.

1. All the temperatures except the exchanger temperature and condenser outlet temperature must be between their low and high limits. The low pressure line temperature can be 'HIGH'.
2. Digital Input 3 (Compressor Fault) is not activated.
3. Digital Input 4 (Compressor Overload) is not activated.
4. Digital Input 5 (Fan Fault) is not activated.
5. Digital Input 6 (Fan Overload) is not activated.
6. Digital Input 7 (Phase Sequence Error) is not activated.
7. Digital Input 8 (Remote Disable) is not activated.
8. Digital Input 11 (High Pressure) is not activated.

9. Digital Input 12 (Low Pressure) is not activated. If all the above conditions are satisfied, the dryer can be started.

## 5. TECHNICAL SPECIFICATIONS

Model	FDRCF1150030	FDRCF1150058
Capacity (scfm)	29	50
Pressure drop (psig)	2,8	1,6
Connection Size	1/2" NPT	3/4" NPT
Amount of Refrigerant (pounds)	0.7	1.2
Refrigerant gas	R134a	R134a
Noise Level (dB)	<70	<70

FOR ALL MODELS	
Nominal Working Pressure	100 psig
Maximum Working Pressure	230 psig
Maximum Ambient Temperature	122°F
Minimum Ambient Temperature	39°F
Maximum Inlet Temperature	140°F

## 6. DIAGRAMS

### 6.1 AIR FLOW DIAGRAMS

#### FDRCF1150030 / FDRCF1150058

POS.	DESCRIPTION	QTY
1	COMPRESSOR	
2	FAN MOTOR	
3	CONDENSER	
4	FAN SWITCH	
5	HIGH PRESSURE SWITCH	
6	LIQUID RECEIVER	
7	FILTER DRYER	
8	EXPANSION VALVE	
9	BY-PASS VALVE	
10	LIQUID SEPARATOR	
11	LOW PRESSURE SWITCH	
12	HEAT EXCHANGER	
13	FILTER	
14	MANUAL VALVE	
15	SOLENOID VALVE	
16	CHECK VALVE	

	<p><b>YOU MUST REGISTER TO ACTIVATE WARRANTY</b></p>		<p><b>Scan or go to website hosted below:</b>  <a href="http://www.eatoncompressor.com/warranty">www.eatoncompressor.com/warranty</a>                      Warranty only valid by following conditions expressed in the Warranty Statement section of this Air Dryer Manual.</p>
-------------------------------------------------------------------------------------	------------------------------------------------------	-------------------------------------------------------------------------------------	------------------------------------------------------------------------------------------------------------------------------------------------------------------------------------------------------------------------------------------------------------------------------------------

## 6.1 AIR FLOW DIAGRAMS

### FDRCF1150030 / FDRCF1150058

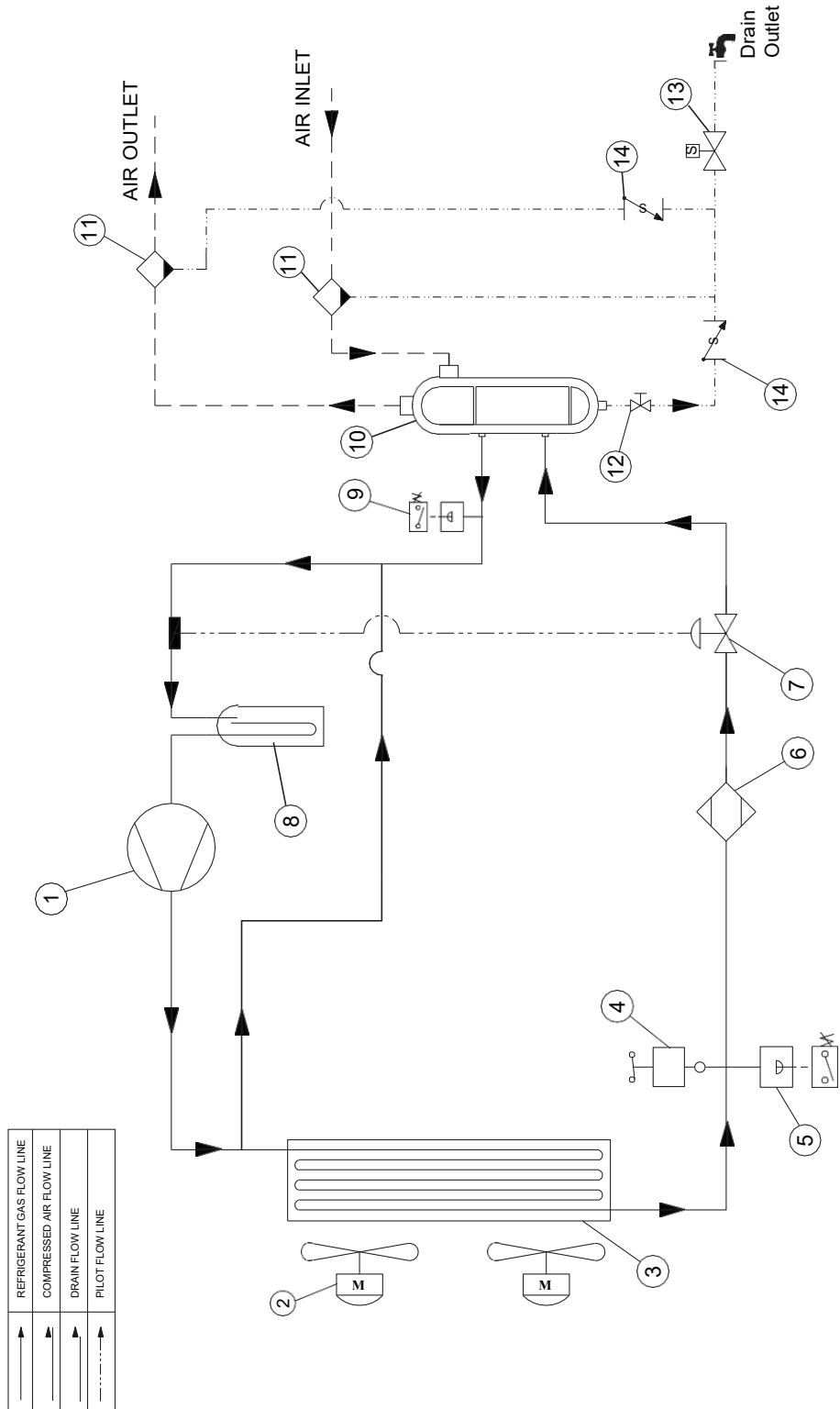

**IMPORTANT NOTICE:**

- High Pressure Switch (Part No:5) is not used on FDRCF1150030.



**YOU MUST REGISTER TO ACTIVATE WARRANTY**



**Scan or go to website hosted below:**

[www.eatoncompressor.com/warranty](http://www.eatoncompressor.com/warranty)

Warranty only valid by following conditions expressed in the Warranty Statement section of this Air Dryer Manual.

## 6.2 ELECTRICAL DIAGRAMS

### With Control & Power

"User must supply the protective earth conductor of the dryer. The conductor is to be connected to the point on the conducting body of the dryer, specified by a sticker with the protective earth symbol next to it. The size of the protective earth conductor should be minimum the size of the power conductor, minimum 16 mm<sup>2</sup> for power conductor size between 16 and 35 mm<sup>2</sup>, minimum half the size of the conductor if it is larger than 35 mm<sup>2</sup>."

Model	FDRCF1150030	FDRCF1150058
Voltage/Phase/Hertz	115/1P/60	115/1P/60
INSTALLED POWER (kWatt)	0.42	0.69
Nominal Current (Amp)	3.92	7.42
MCA (A)	5.11	9.20
TOTAL LRA (A)	22.48	33.70
Fuse (Amp)	6	10

## 6.2 ELECTRICAL DIAGRAMS

### FDRCF1150030

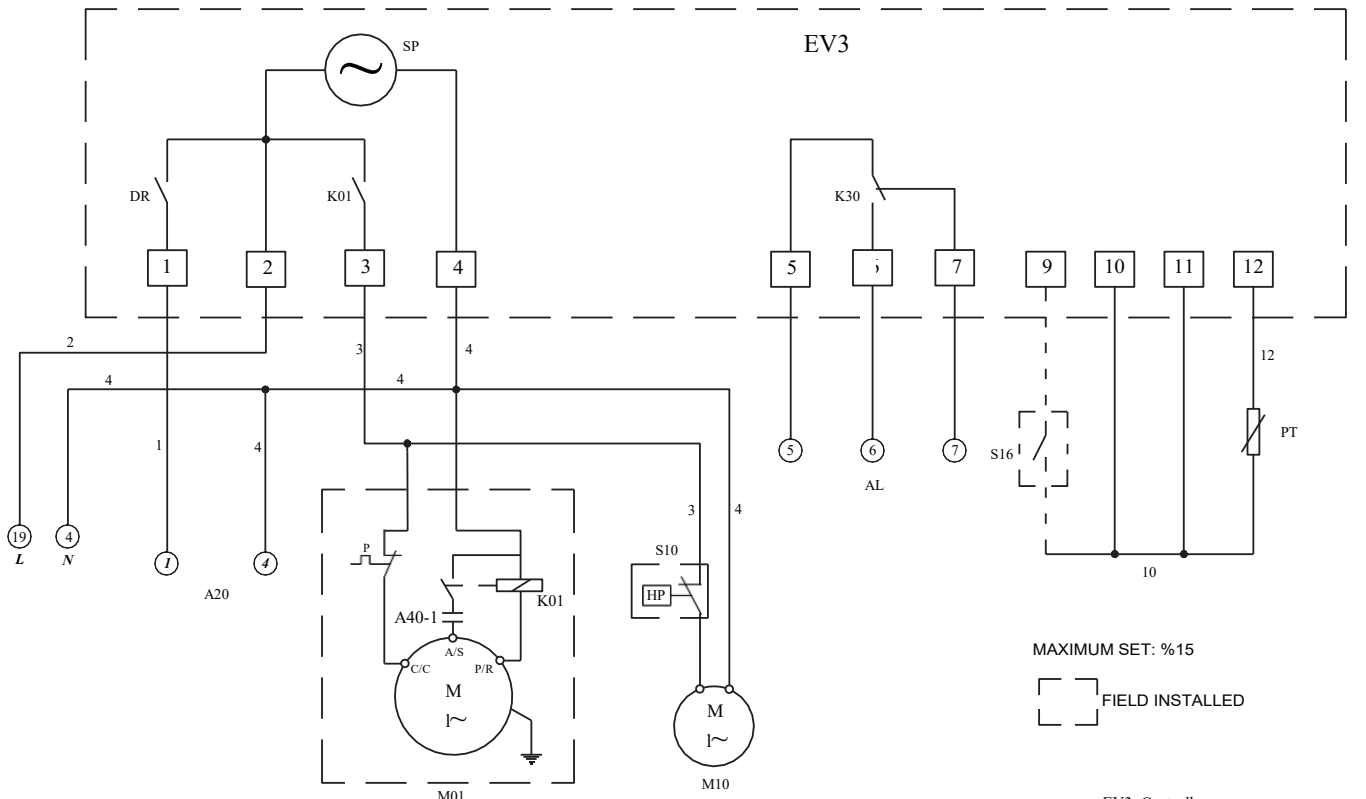

#### ELECTRICAL SPECIFICATIONS

COMPRESSOR UN 115V/1~/60Hz FAN MOTOR UN 115V/1~/60Hz  
 FDRCF1150030 RLA 3,7A 0,285kW FDRCF1150030 RLA 0,35A 0,055kW

**S01 MAIN PROTECTION AND DISCONNECTING MEANS SHALL BE PROVIDED BY THE INSTALLER OF RESIDUAL CURRENT AUTOMATIC CIRCUIT BREAKER**

SUPPLY LINE VOLTAGE RATING - 600 VAC

ELECTRICAL SUPPLY LINE SINGLE PHASE + PROTECTION EARTH
CABLES SIZE
FDRCF1150030 3AWG14

MAXIMUM SET: 9/15

FIELD INSTALLED

EV3: Controller  
 SP: Power supply  
 AL: Alarm contacts  
 A20: Drain supply  
 DR: Drain valve relay  
 A40-1: Start capacitor  
 K01: Compressor start relay  
 K02: Compressor motor contactor  
 K30: Alarm relay  
 S10: Fan pressure switch  
 S16: Filter service contact (optional)  
 M01: Compressor motor  
 M10: Fan motor  
 P: Compressor motor overload protector  
 PT: Temperature sensor (NTC)  
 HP indicates high pressure.



Scan or go to website hosted below:

[www.eatoncompressor.com/warranty](http://www.eatoncompressor.com/warranty)

Warranty only valid by following conditions expressed in the Warranty Statement section of this Air Dryer Manual.

## 6.2 ELECTRICAL DIAGRAMS

### FDRCF1150058

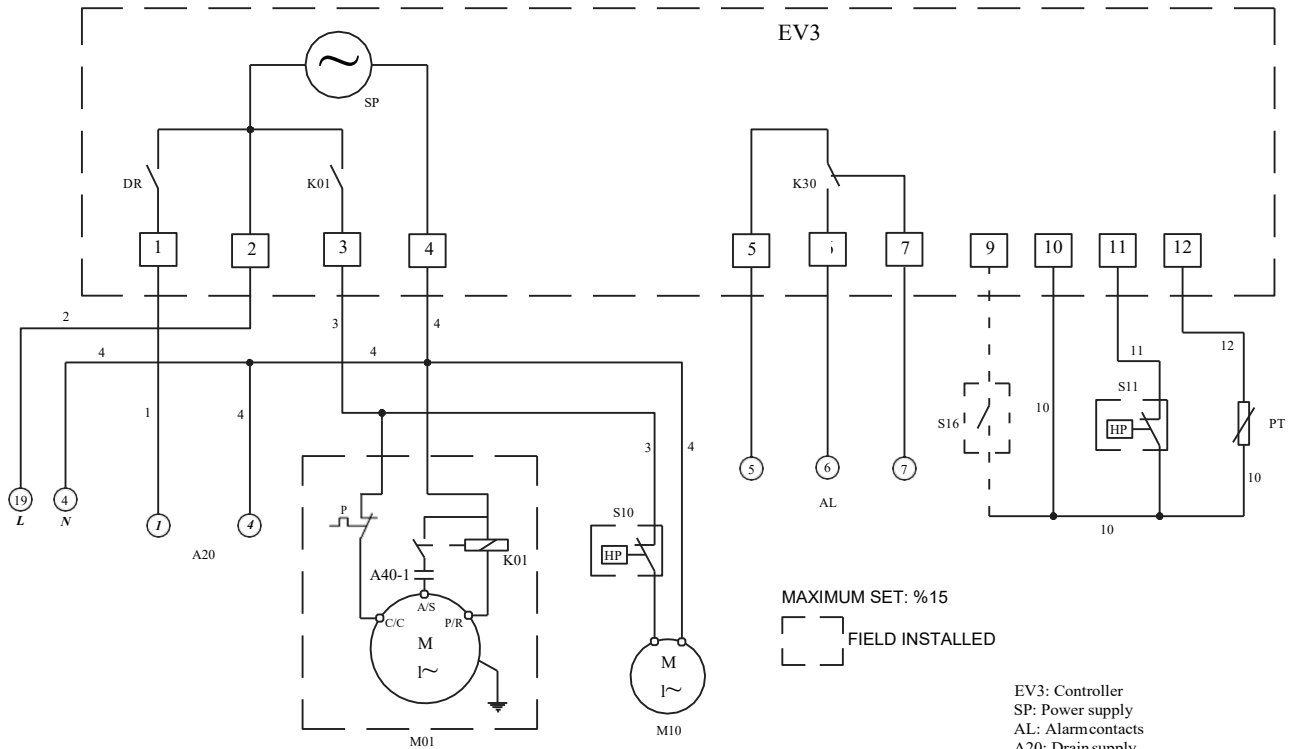

**ELECTRICAL SPECIFICATIONS**

**COMPRESSOR**  
UN 115V/1~/60Hz  
FDRCF1150058 RLA 6A 0,466kW

**FAN MOTOR**  
UN 115V/1~/60Hz  
FDRCF1150058 RLA 0,95A 0,110kW

**S01 MAIN PROTECTION AND DISCONNECTING MEANS SHALL BE PROVIDED BY THE INSTALLER OF RESIDUAL CURRENT AUTOMATIC CIRCUIT BREAKER**

SUPPLY LINE VOLTAGE RATING - 600 VAC

ELECTRICAL SUPPLY LINE	
SINGLE PHASE + PROTECTION EARTH	
	CABLES SIZE
FDRCF1150058	3AWG14

MAXIMUM SET: %15  
FIELD INSTALLED

- EV3: Controller
- SP: Power supply
- AL: Alarmcontacts
- A20: Drain supply
- DR: Drain valve relay
- A40-1: Start capacitor
- K01: Compressor start relay
- K02: Compressor motor contactor
- K30: Alarm relay
- S10: Fan pressure switch
- S11: High pressure switch
- S16: Filter service contact (optional)
- M01: Compressor motor
- M10: Fan motor
- P: Compressor motor overload protector
- PT: Temperature sensor (NTC)
- HP indicates high pressure



Scan or go to website hosted below:

[www.eatoncompressor.com/warranty](http://www.eatoncompressor.com/warranty)

Warranty only valid by following conditions expressed in the Warranty Statement section of this Air Dryer Manual.

## 7. ID DIAGRAM DRAWINGS & GENERAL ARRANGEMENTS

### 7.1 ID DIAGRAM DRAWINGS

FDRCF1150030 / FDRCF1150058

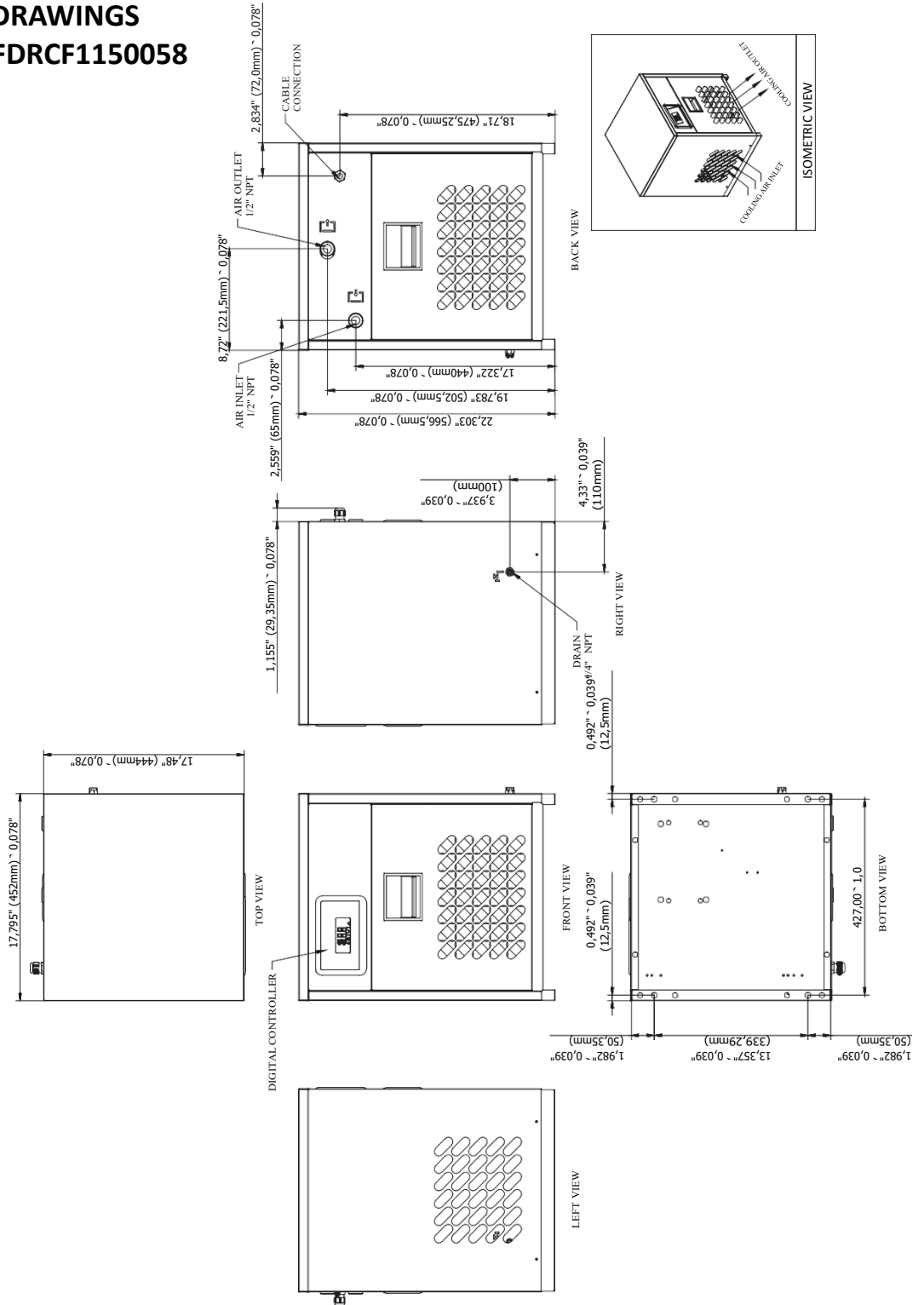

**STOP**  
**YOU MUST REGISTER TO ACTIVATE WARRANTY**



**Scan or go to website hosted below:**  
[www.eatoncompressor.com/warranty](http://www.eatoncompressor.com/warranty)

Warranty only valid by following conditions expressed in the Warranty Statement section of this Air Dryer Manual.



## 7.2 ID DIAGRAM DRAWINGS FDRCF1150030 / FDRCF1150058

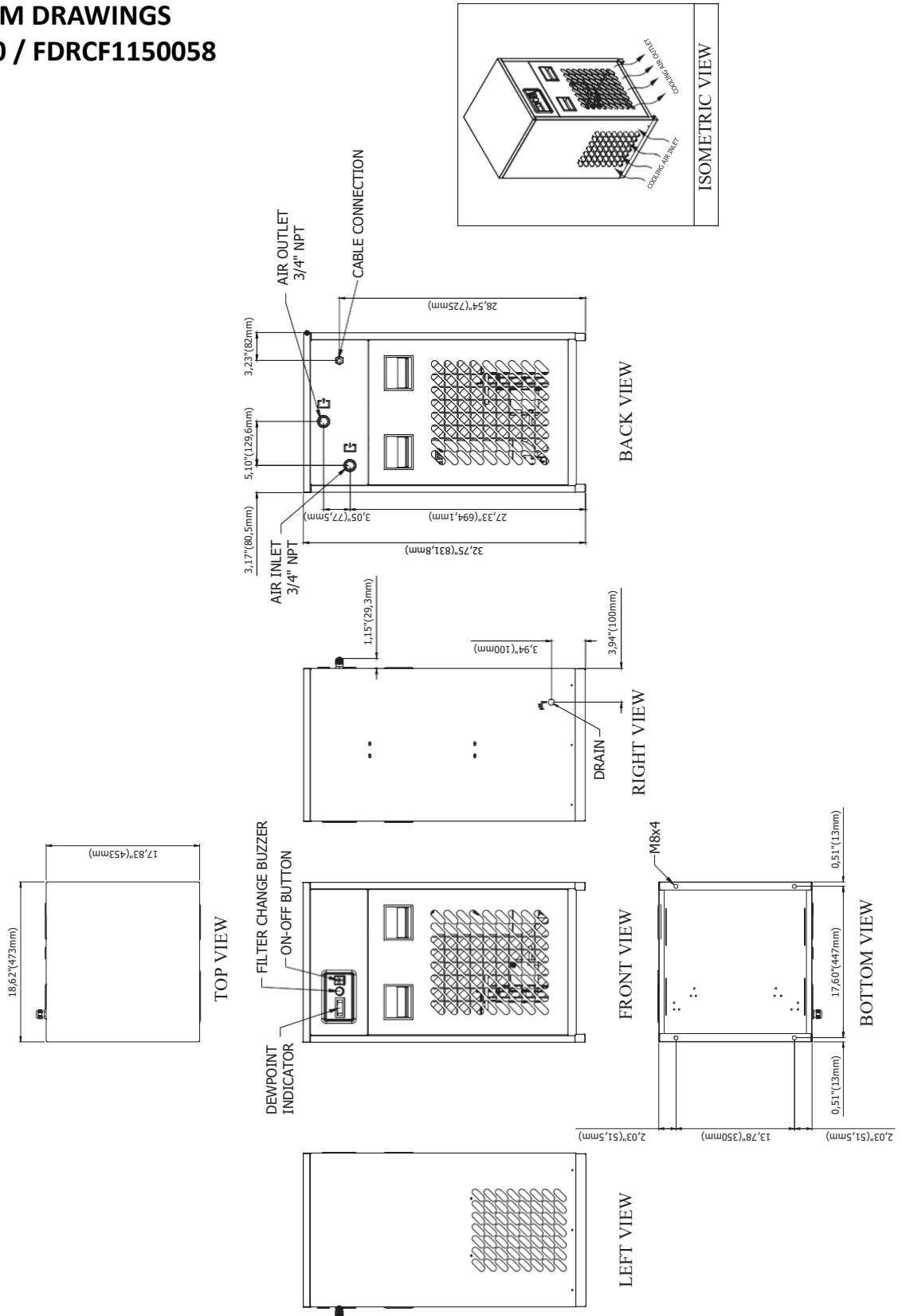

**STOP**  
 YOU MUST REGISTER TO ACTIVATE WARRANTY



**Scan or go to website hosted below:**  
[www.eatoncompressor.com/warranty](http://www.eatoncompressor.com/warranty)  
 Warranty only valid by following conditions expressed in the Warranty Statement section of this Air Dryer Manual.

## 7.3 GENERAL ARRANGEMENTS

### FDRCF1150030 / FDRCF1150058

Model	Element Type	Length (inch)	Width (inch)	Height (inch)	Weight (lbs)
FDRCF1150030	FILTERKIT011	17.48	17.79	22.30	72.00
FDRCF1150058	FILTERKIT012	17.83	18.62	32.76	116.60

ALL MODELS	Superheat of thermostatic expansion valve	Evaporating pressure	Fan pressure switch	Security high pressure switch	Security low pressure switch	Drain Timer	Refrigerant temperature switch	Water flow valve (if water condenser)
	41.0°F - 50.0°F	29.7 psi	130.5 - 174 psi	162.5 psi	23.2 psi	5 min. - 5 sec.	113°F	159.5 psi

## 8. FDRCF EXPLODED DIAGRAMS & SPARE PARTS LISTS

### 8.1 - ED & Spare Part List

#### FDRCF1150030

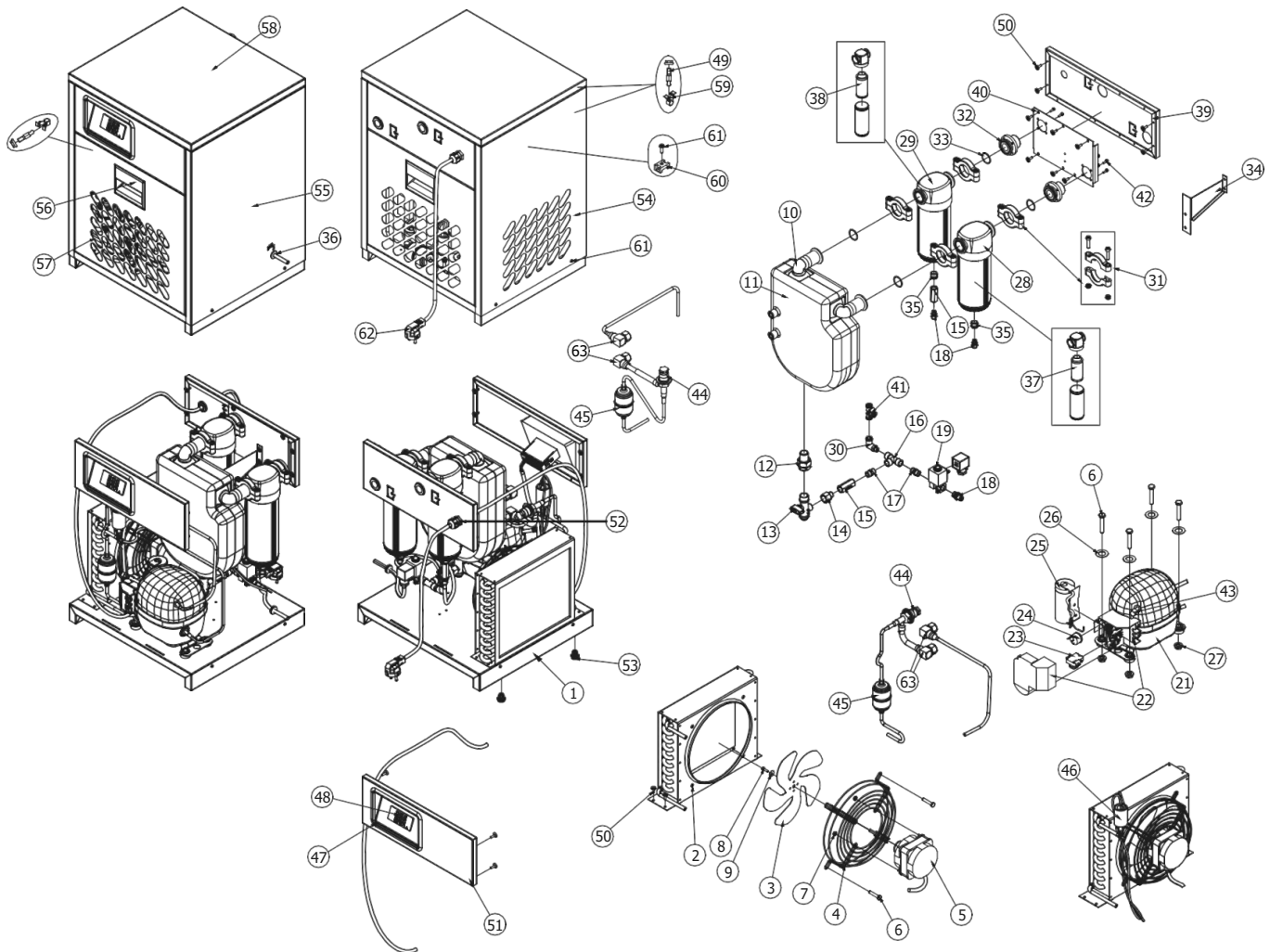



**YOU MUST REGISTER TO ACTIVATE WARRANTY**



**Scan or go to website hosted below:**  
[www.eatoncompressor.com/warranty](http://www.eatoncompressor.com/warranty)  
 Warranty only valid by following conditions expressed in the Warranty Statement section of this Air Dryer Manual.

## 8.1 - ED & Spare Part List FDRCF1150030

PART LIST					
DWG SIZE	ITEM NO.	PART NO.	DESCRIPTION	REV	QTY.
	1	MK30E-CAB	CABINET BASE		1
	2	MK30E-CON	CONDENSER		1
	3	M-FAN-0075	FAN BLADE		1
	4	M-GRL-0075	FAN GRILL		1
	5	M-FMT-0075-115-1-60	FAN MOTOR		1
	6	MK260E-BLT630	BOLT M6x30mm		8
	7	MK110E-NT4	NUT M4		4
	8	MK110E-BLT414	BOLT M4x14mm		1
	9	MK110E-WHR20	WASHER 20x4,3x1,5		1
	10	MK30E-EXC	HEAT EXCHANGER		1
	11	MK30E-IHE	INSULATION OF HEAT EXCHANGER		1
	12	MK260E-RCD	1/2" RECORD		1
	13	M-DBV-0200	DRAIN BALL VALVE		1
	14	MK150E-RDC	REDUCTION 3/8" - 1/4"		1
	15	MK170E-CHV	CHECK VALVE		2
	16	MK170E-T1/4	1 / 4" T CONNECTOR		1
	17	MK170E-NIP1/4	1 / 4" NIPPLE		2
	18	MK150E-FIT6	1 / 4" - 6mm FITTINGS		3
	19	M-SLV-0150-115	SOLENOID VALVE		1
	20	N/A	N/A		-
	21	M-CMP-0035-115-1-60	COMPRESSOR		1
	22	MK40E-CEC	COMPRESSOR ELECTRICAL BOX COVER		1
	23	M-CSR-0035-115-1-60	COMPRESSOR START RELAY		1
	24	M-COP-0035-115-1-60	COMPRESSOR OVERLOAD PROTECTOR		1
	25	M-CSC-0035-115-1-60	COMPRESSOR START CAPACITOR		1
	26	MK30E-WSR18	WASHER 18x7x1mm		4
	27	MK30E-NT6	NUT M6		4
	28	MK30E-ELK-Y	COMPRESSED AIR FILTER KIT (Y)		1
	29	MK30E-ELK-X	COMPRESSED AIR FILTER KIT (X)		1
	30	MK170E-EWF	90* 1 / 4" - 6mm ELBOW		1
	31	MK30E-CPG	COUPLING CLAMP		4

PART LIST					
DWG SIZE	ITEM NO.	PART NO.	DESCRIPTION	REV	QTY.
	32	MK30E-CNK-NPT	CONNECTION CIT		2
	33	MK30E-ORG	O-RING		4
	34	MK30E-EXS	HEAT EXCHANGER SUPPORT STEEL		1
	35	MK260E-RDC	REDUCTION 1 / 2" - 1 / 4"		1
	36	MK90E-GFD	GASKET FOR DRAIN		1
	37	MK30E-FIE-X	COMPRESSED AIR FILTER ELEMENT (X)		1
	38	MK30E-FIE-Y	COMPRESSED AIR FILTER ELEMENT (Y)		1
	39	MK30E-CRT	CABINET REAR TOP		1
	40	MK30E-CAI	CABINET INSIDE		1
	41	MK35E-FTT-T	TEE FITTING		1
	42	MK60E-BLT48	BOLT M4x8		8
	43	MK260E-STC	SETTING THE CONNECTION		1
	44	M-BYV-0100	EXPANSION VALVE		1
	45	M-DRI-0200	DRYER-DEHYDRATOR		1
	46	M-FNS-0200	FAN ON/OFF SWITCH		1
	47	MK260E-PCP	PLASTIC CONTROL PANEL		1
	48	MK130E-DPI-115	DIGITAL CONTROLLER		1
	49	M-STU-6000	CABINET STUD AND NUT		8
	50	MK90E-BLT412	BOLT M4x12		18
	51	MK30E-COP	CONTROLLER PANEL		1
	52	MK260E-CG11	CABLE GLAND PG11		1
	53	MK260E-RNT8	RIVET NUT M8		4
	54	MK30E-CLT	CABINET LEFT		1
	55	MK30E-CBR	CABINET RIGHT		1
	56	M-CHN-6000	CABINET HANDLE (NEW)		2
	57	MK30E-CSG	CABINET STRIPPING		2
	58	MK30E-CAT	CABINET TOP		1
	59	M-FAS-6000	CABINET FASTENER		8
	60	MK90E-CSP	CABLE STRAP		3
	61	MK90E-RVT3,5	RIVET Ø3,5		25
	62	MK130E-PWC	POWER CABLE		1
	63	MK60E-RTA2	ROTOLOCK ADAPTOR2		2

	<p><b>YOU MUST REGISTER TO ACTIVATE WARRANTY</b></p>		<p><b>Scan or go to website hosted below:</b>  <a href="http://www.eatoncompressor.com/warranty">www.eatoncompressor.com/warranty</a>                      Warranty only valid by following conditions expressed in the Warranty Statement section of this Air Dryer Manual.</p>
-------------------------------------------------------------------------------------	------------------------------------------------------	-------------------------------------------------------------------------------------	------------------------------------------------------------------------------------------------------------------------------------------------------------------------------------------------------------------------------------------------------------------------------------------

### 8.1 - ED & Spare Part List FDRCF1150058

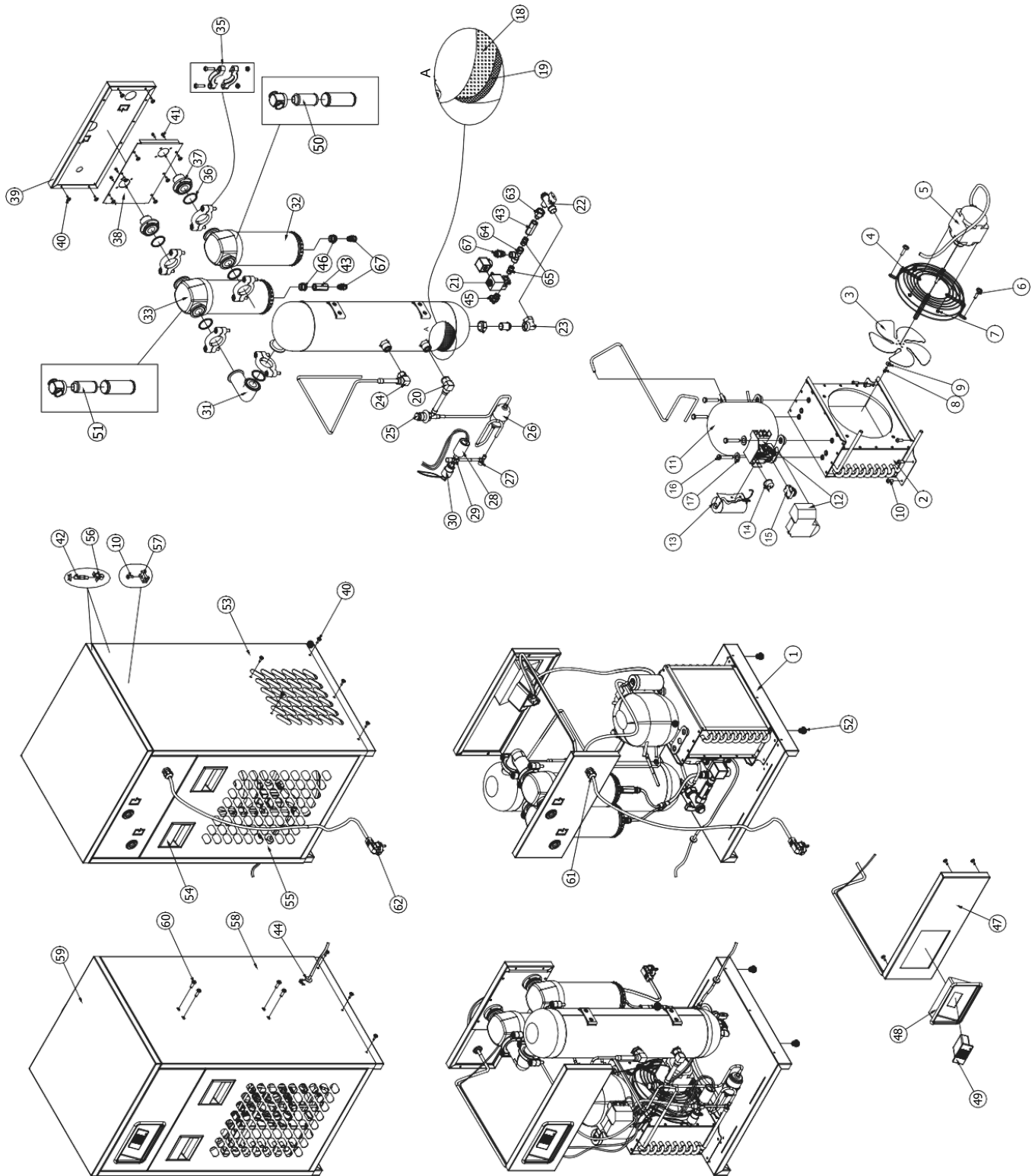

	<b>YOU MUST REGISTER TO ACTIVATE WARRANTY</b>		<b>Scan or go to website hosted below:</b>
			<a href="http://www.eatoncompressor.com/warranty">www.eatoncompressor.com/warranty</a>
Warranty only valid by following conditions expressed in the Warranty Statement section of this Air Dryer Manual.			

## 8.1 - ED & Spare Part List FDRCF1150058

PART LIST					
DWG SIZE	ITEM NO.	PART NO.	DESCRIPTION	REV	QTY.
	1	MK60E-CAB	CABINET BASE		1
	2	MK60E-CON	CONDENSER		1
	3	M-FAN-0150	FAN BLADE		1
	4	M-GRL-0150	FAN GRILL		1
	5	M-FMT-0150-115-1-60	FAN MOTOR		1
	6	MK260E-BLT630	BOLT M6x30		4
	7	MK110E-NT4	NUT M4		4
	8	MK110E-BLT414	BOLT M4x14mm		1
	9	MK110E-WHR20	WASHER Ø20xØ4,3x1,5		1
	10	MK90E-RVT3,5	RIVET Ø3,5		9
	11	M-CMP-0035-115-1-60-H	COMPRESSOR		1
	12	MK50E-CEC	COMPRESSOR ELECTRICAL BOX COVER		1
	13	M-CSC-0035-115-1-60	COMPRESSOR START CAPACITOR		1
	14	M-COP-0035-115-1-60-H	COMPRESSOR OVERLOAD PROTECTOR		1
	15	M-CSR-0035-115-1-60	COMPRESSOR START RELAY		1
	16	MK150E-BLT840	BOLT M8x40		4
	17	MK260E-WHR22	WASHER Ø22xØ8,5x2,5		4
	18	MK60E-EXC	HEAT EXCHANGER		1
	19	MK60E-IHE	INSULATION OF HEAT EXCHANGER		1
	20	MK60E-RTA2	ROTOLOCK ADAPTOR2		1
	21	M-SLV-0150-115	SOLENOID VALVE		1
	22	M-DBV-0200	DRAIN BALL VALVE		1
	23	MK260E-ELW2	ELBOW 2		1
	24	MK70E-RTA3	ROTOLOCK ADAPTOR3		1
	25	M-BYV-0100	EXPANSION VALVE		1
	26	M-DRI-0200	DRYER-DEHYDRATOR		1
	27	MK90E-CPT1	CUPPER T1		1
	28	M-FNS-0200	FAN ON/OFF SWITCH		1
	29	MK90E-TDP	ADAPTOR T		1
	30	M-HPS-0200	HIGH PRESSURE SWITCH		1
	31	MK60E-CNK1	CONNECTION CIT1		1
	32	MK60E-ELK-X	COMPRESSED AIR FILTER KIT (X)		1

PART LIST					
DWG SIZE	ITEM NO.	PART NO.	DESCRIPTION	REV	QTY.
	33	MK60E-ELK-Y	COMPRESSED AIR FILTER KIT (Y)		1
	34	N/A	N/A		-
	35	MK60E-CPG	COUPLING CLAMP		5
	36	MK60E-ORG	O-RING		5
	37	MK60E-CNK2-NPT	CONNECTION CIT2		2
	38	MK60E-CAI	CABINET INSIDE		1
	39	MK60E-CRT	CABINET REAR TOP		1
	40	MK90E-BLT412	BOLT M4x12		8
	41	MK60E-BLT48	BOLT M4x8		2
	42	M-STU-6000	CABINET STUD AND NUT		8
	43	MK170E-CHV	CHECK VALVE		1
	44	MK90E-GFD	GASKET FOR DRAIN		1
	45	MK170E-EWF	90* 1 / 4" - 6mm ELBOW		1
	46	MK260E-RDC	REDUCTION 1 / 2" - 1 / 4"		2
	47	MK60E-COP	CONTROLLER PANEL		1
	48	MK260E-PCP	PLASTIC CONTROL PANEL		1
	49	MK130E-DPI-115	DIGITAL CONTROLLER		1
	50	MK60E-FIE-X	COMPRESSED AIR FILTER ELEMENT (X)		1
	51	MK60E-FIE-Y	COMPRESSED AIR FILTER ELEMENT (Y)		1
	52	MK260E-RNT8	RIVET NUT M8		1
	53	MK60E-CLT	CABINET LEFT		4
	54	M-CHN-6000	CABINET HANDLE (NEW)		4
	55	MK60E-CSG	CABINET STRIPPING		2
	56	M-FAS-6000	CABINET FASTENER		8
	57	MK90E-CSP	CABLE STRAP		1
	58	MK60E-CBR	CABINET RIGHT		1
	59	MK60E-CAT	CABINET TOP		4
	60	MK90E-BLT615	BOLT M6x15		1
	61	MK260E-CG11	CABLE GLAND PG11		1
	62	MK130E-PWC	POWER CABLE		1
	63	MK150E-RDC	REDUCTION 3/8" - 1/4"		1
	64	MK170E-T1/4	1 / 4" T CONNECTOR		1
	65	MK170E-NIP1/4	1 / 4" NIPPLE		2
	66	N/A	N/A		-
	67	MK150E-FIT6	1 / 4" - 6mm FITTINGS		3

	<p><b>YOU MUST REGISTER TO ACTIVATE WARRANTY</b></p>		<p><b>Scan or go to website hosted below:</b>  <a href="http://www.eatoncompressor.com/warranty">www.eatoncompressor.com/warranty</a>                      Warranty only valid by following conditions expressed in the Warranty Statement section of this Air Dryer Manual.</p>
-------------------------------------------------------------------------------------	------------------------------------------------------	-------------------------------------------------------------------------------------	------------------------------------------------------------------------------------------------------------------------------------------------------------------------------------------------------------------------------------------------------------------------------------------

## 9. COMPONENTS LOCATION

All main components located into dryer identified with labels as listed below.

CAUTION: Due to manufacturer design, some components out of the list are not installed into the dryer.

### Electrical components:

#### Accessories:

- A01: Control circuit transformer
- A02: Power circuit transformer
- A10: ON warning light
- A11: OFF warning light
- A20: Drain solenoid valve
- A30: Crankcase heater
- A31: Electrical resistor
- A40: Electrical capacity
- EV3: Digital Controller (Digi-Pro)
- A50-3: Energy saving device 3 (ESD3)

#### Relays:

- K01: Compressor motor relay
- K10: Fan motor relay
- K20: Drain timer or Bekomat (optional)
- K30: Temperature Controller

#### Switches:

- S01: Main switch
- S02: Start push button
- S03: Stop push button
- S10: Fan pressure control
- S11: High-low pressure security control
- S12: High pressure security control
- S13: Low pressure security control
- S20: Refrigerant temperature control
- S21: Air temperature control

#### Motors:

- M01: Refrigerant compressor motor
- M10: Fan motor

#### Thermal protections:

- P01: Refrigerant compressor thermal overload
- P10: Fan motor thermal overload

#### Fuses protections:

See complete identification into electrical sketch included in dryer

- F--: Transformer protection
- F--: Fan protection
- F--: Compressor relay protection
- F--: Transformer protection
- F--: Drain protection
- F--: Fan relay protection

#### Refrigerant components:

- G01: Liquid receiver
- G02: Refrigerant dryer
- G03: Expansion valve
- G04: Liquid separator
- G05: Hot gas bypass valve
- G06: Refrigerant solenoid valve
- G10: Water cooled condenser
- G11: Water control valve
- G20: Refrigerant evaporating pressure gauge
- G21: Refrigerant evaporating temperature gauge

#### Compressed air components:

- H01: Air inlet prefilter
- H11: Drain filter
- H12: Pneumatic drain valve

#### Terminal boxes:

- B01: Main terminal box
- B11: Refrigerant terminal box
- B12: Free of potential terminal box

	<b>YOU MUST REGISTER TO ACTIVATE WARRANTY</b>		<b>Scan or go to website hosted below:</b> <a href="http://www.eatoncompressor.com/warranty">www.eatoncompressor.com/warranty</a> Warranty only valid by following conditions expressed in the Warranty Statement section of this Air Dryer Manual.
-------------------------------------------------------------------------------------	-----------------------------------------------	-------------------------------------------------------------------------------------	-----------------------------------------------------------------------------------------------------------------------------------------------------------------------------------------------------------------------------------------------------------

## 10. Troubleshooting

Problem	Possible Cause	Repair	Comments
Dryer is switched on, indicator light is lit but the refrigerant compressor does not turn on.	The connection has inverted phases.	Invert two phases.	3-phase dryers are equipped with a phase controller to avoid the fans from turning in the opposite direction.
	Refrigeration unit is not functioning.	Check refrigeration compressor.	Several factors can cause compressor failure. A qualified refrigeration technician needs to check all the electrical and refrigerant circuit and controls.
	The refrigerant high pressure protection has tripped.	The refrigerant safety high pressure switch has tripped.	The dryer is protected against excessively high refrigerant pressure. If the condenser efficiency has reduced, the switch will trip. Manually reset the switch.
		In case of water cooled condensers, check the water control valve.	
Excessive ambient temperature.	Be sure that dryer is working in temperatures lower than the designed conditions. Designed conditions and correction factors are described in this manual.	A high ambient temperature may cause the refrigerant system to operate at higher than normal pressures. Results will be higher than normal evaporator temperature. Important: adequate air circulation around the dryer, and proper ventilation in the equipment room should guarantee a low enough ambient temperature.	
Dryer is switched on, but the refrigerant compressor does not turn on.	Excessive temperature on crankcase of compressor.	Allow time for compressor to cool down. May be a possible incorrect adjustment of hot gas bypass valve or shortage of refrigerant.	Compressor is protected against overly high temperatures of the crankcase by a thermal switch.
	Excessive compressed air inlet temperature.	Be sure that dryer is working in temperatures lower than designed conditions.	The dryer is designed for working in calculated conditions (see description in this manual). If conditions are exceeded, the dryer will be overflowed, dew point will go up and protecting devices can switch off.
	Clogged condenser fins or clogged water condenser. Possible high crankcase temperature. Possible loss of phase. Possible low voltage causing overload trip. Possible failed compressor.	Clear fins of water condenser of all obstructions.	The clogged fins in the condenser will restrict the air passage and reduce the refrigeration capacity, causing high temperature in the evaporator. Same will occur if water condenser is clogged with mud or dirt. Air condenser and water condenser should be periodically checked and cleaned. Protect water circuit by an adapted filter.
	Too much compressed air flow.	Check actual flow through the dryer.	This dryer is designed for a maximum air flow at design conditions. If too much air is pumped into the dryer, water removal capacity may not be sufficient, resulting in liquid carryover down stream. Check the rated output the air compressor.
	Faulty electrical wiring.	Inspect the circuit.	The compressor-on light should be wired into the refrigerant compressor circuit. See wiring diagrams in this manual.
	One electrical protection has tripped.	Reset the protection or replace the blown fuse.	The dryer is protected against high amp draw by fuse and/or overload relay that can trip in case of need. Reset or replace fuse once, but do not persist if it trips again, request assistance from a qualified refrigeration contractor.
Dryer is switched on but the fan is not running.	Fan has to run if refrigerant high pressure reaches upper set point.	Check that compressor air flows through the dryer. Check that fan blades are free to move. Check the fan pressure switch.	Fan operates automatically to keep refrigerant pressure below the maximum value. The fan can stop if pressure is under the recommended setting.
When compressor starts, it vibrates a lot and makes mechanical noise.	Compressor is slugging liquid refrigerant at start up.	Be sure the preheating period of at least 2 hours is respected.	Refrigerant may move between receivers when refrigerant compressor is stopped and not heated, especially if stopped for a long time. This migration may cause liquid shock (slugging) in valves specially on large dryers containing more refrigerant.

	<p><b>YOU MUST REGISTER TO ACTIVATE WARRANTY</b></p>		<p><b>Scan or go to website hosted below:</b>  <a href="http://www.eatoncompressor.com/warranty">www.eatoncompressor.com/warranty</a>                      Warranty only valid by following conditions expressed in the Warranty Statement section of this Air Dryer Manual.</p>
-------------------------------------------------------------------------------------	------------------------------------------------------	-------------------------------------------------------------------------------------	------------------------------------------------------------------------------------------------------------------------------------------------------------------------------------------------------------------------------------------------------------------------------------------

Problem	Possible Cause	Repair	Comments
Water in system.	Compressed Air Inlet and outlet connections are reversed.	Check inlet and outlet connections.	This dryer is designed for air flow in one direction only. Inlet and outlet directions are identified on the dryer.
	Drain system is clogged or inoperative.	Restore a free flow of water condensate. Check water evacuation.	Drain system is on timed solenoid valve, pneumatically assisted which has to be adjusted in accordance with values listed in this manual. The solenoid valve includes a strainer that has to be periodically checked and cleaned. Membranes of pneumatically assisted drain have to be checked or replaced every 6 months.
	Bypass system is open.	Check the valves.	Important: Bypass piping should be installed around the dryer so the dryer can be isolated for service without shutting down the air supply. During dryer operation, valves must be set so all air goes into the system. Check tightness of the bypass system.
	Free moisture remains in pipe lines.	Blow out the system.	Before the dryer is first started all free moisture should be blown out of the system.
	Excessive air flow.	Check actual flow through the dryer.	This dryer is designed for a maximum air flow. If too much air is pumped into the dryer, water removal capacity may not be sufficient, resulting in liquid carry over downstream. Check the rated flow of the air compressor.
	Excessive free moisture.	Check the separator and drain system and compressor after cooler ahead of the dryer.	In some systems there may be an accumulation of free moisture in the line ahead of the dryer. If this moisture is pumped into the dryer intermittently, the water removal capacity may not be sufficient. A water separator should be installed in the line before the dryer.
	Excessive compressed air inlet temperature.	Be sure that dryer is working lower than designed conditions.	The dryer is designed to work for calculated design conditions. Should the conditions be exceeded, the dryer will be overflowed, dew point will go up and protecting devices can switch off.
	Clogged condenser fins.	Clear fins of all obstructions.	The clogged fins in the condenser will restrict air passage and reduce refrigerant capacity causing water downstream. Fins should be periodically checked and cleaned.
	Shortage of refrigerant.	Fix the leak and add a charge of refrigerant.	Loss of refrigerant will cause improper functioning. A qualified, refrigeration specialist should perform the necessary repairs, or factory should be contacted if the unit is under warranty.
	Refrigeration system is not functioning.	Check to be certain refrigerant compressor is running.	To check if the compressor is running, check compressor on light. It is possible for the fan to be operating but not the compressor. Compressor not running can be caused by several factors. A qualified refrigeration technician should check all refrigerant and electrical controls.
High pressure drop.	Excessive compressed air flow or too low air inlet pressure.	Check actual pressure and flow through the dryer.	This dryer is designed for a maximum air flow. If too much air is pumped into the dryer, water removal capacity may not be sufficient, resulting in liquid carryover downstream. Check the rated flow of the air compressor.
	Freeze up.	Check that compressor room ambient.	Frosting of the lines is an indication that controls are set too low. The following should be done by an experienced refrigeration technician.
		Fan switch could have failed in closed position keeping fan on.	Controls may be adjusted in the fields by means of the hot gas bypass valve. This is to be done by a qualified refrigerant technician.

	<p><b>YOU MUST REGISTER TO ACTIVATE WARRANTY</b></p>		<p><b>Scan or go to website hosted below:</b>  <a href="http://www.eatoncompressor.com/warranty">www.eatoncompressor.com/warranty</a>                      Warranty only valid by following conditions expressed in the Warranty Statement section of this Air Dryer Manual.</p>
-------------------------------------------------------------------------------------	------------------------------------------------------	-------------------------------------------------------------------------------------	------------------------------------------------------------------------------------------------------------------------------------------------------------------------------------------------------------------------------------------------------------------------------------------



Problem	Possible Cause	Repair	Comments
The unit will not run or cycles off and on.	Clogged heat exchanger.	Clean heat exchanger with a reverse air flow.	Dryer is supposed to be used with compressed air free of any aggressive contaminants. Some contamination may require extra maintenance of the heat exchanger.
	Line disconnect switch is open.	Close the start or disconnect switch.	If the dryer is not operating, check the disconnect switch or circuit breaker to be certain it is on.
	Fuse or breaker is open.	Replace fuse or reset breaker.	The fuse to the power line should be checked and replaced if needed. Never replace a burnt fuse with an oversized fuse.
	Faulty refrigerant compressor or controls.	Determine the cause and make correction.	Failure of compressor to run may be caused by several factors. A qualified refrigeration specialist should check all electrical and refrigeration controls, or factory should be contacted if unit is under warranty.
	Excessive compressed air inlet temperature.	Designed conditions and correction factors are described in this manual. Be sure that dryer is working in ambient temperatures below designed conditions.	The dryer is designed for working into calculated design conditions. Should the conditions be exceeded, the dryer will be overflowed, dew point will go up and protecting devices may trip.
	Excessive ambient temperature.	Designed conditions and correction factors are described in dryer. Be sure that dryer is working lower than designed conditions.	A high ambient temperature may cause the refrigerant system to operate at higher than normal pressures. Results will be a higher than normal evaporator temperature. Important: There should be adequate air circulation around the dryer, and proper ventilation in the equipment room should guarantee a low enough ambient temperature.
	Clogged condenser fins.	Clear fins of all obstructions.	The clogged fins in the condenser will restrict the air passage and reduce the refrigeration capacity, causing high temperature in the evaporator. Fins should be periodically checked and cleaned.
	Low refrigerant level.	Fix the leak and add a charge of refrigerant.	Loss of refrigerant will cause improper functioning. Dryers are equipped with a temperature switch which maintains the amount of refrigerant to maintain proper cooling of the compressor. A shortage of refrigerant may cause suction line to become very hot, causing the temperature switch to trip. A qualified refrigeration specialist should perform the necessary repairs.
Error sign occurs on digital temperature control device.	The dew point is too low or too high.	Check refrigerant gas and make sure that the working conditions are within the correct range.	If there is not enough refrigerant gas or if the working temperature and inlet temperatures are very high, the dew point will increase.
Drain failure.	Back pressure or reduction of drain port.	Replace the drain(s). Open drain to atmosphere (no back pressure) - if hose / pipe is used to carry the drain somewhere else, keep or enlarge the diameter.	Max. drain hose length after the dryer must not exceed 30 feet.
			Max. drain hose height from the dryer must not exceed 9 feet.
			The drain port size should not be reduced.
			There should not be any fitting that may cause pressure drop such as valves, elbow, tees, etc. on the drain connection.
			Drain should be at atmospheric pressure at all times. Any back pressure will result in failure and malfunction.

**DRYER FILTER MAINTENANCE KITS**

Part Number	Description	Filter Maintenance Kit
FDRCF1150030	Dryer 30 CFM	FILTERKIT011
FDRCF1150030	Dryer 30 CFM SN#1418MA - 3320MA	FKIT011A
FDRCF1150030	Dryer 30 CFM SN#3420MA or greater	FKIT011B
FDRCF1150058	Dryer 58 CFM	FILTERKIT012
FDRCF1150058	Dryer 58 CFM SN#0420MA or greater	FKIT012A

	<p><b>YOU MUST REGISTER TO ACTIVATE WARRANTY</b></p>		<p><b>Scan or go to website hosted below:</b>  <a href="http://www.eatoncompressor.com/warranty">www.eatoncompressor.com/warranty</a>                      Warranty only valid by following conditions expressed in the Warranty Statement section of this Air Dryer Manual.</p>
-------------------------------------------------------------------------------------	------------------------------------------------------	-------------------------------------------------------------------------------------	------------------------------------------------------------------------------------------------------------------------------------------------------------------------------------------------------------------------------------------------------------------------------------------

## 11. CHECK VALVE MAINTENANCE (CB20100F / CB20200F MODELS)



**Figure 1:**

The check valve is an integral piece to the compressor being able to pump and hold air. It is located on the back of the tank. Prior to any maintenance on the system the air must be fully released. This can be done by opening the over pressure relief valve or using an air gun to drain the tank.



**Figure 2:**

There is a removable cap on the check valve. This should be easily removed with a wrench. CAUTION: There is a spring inside this cap. It is not a strong spring but could spring out and be lost if you are not careful.

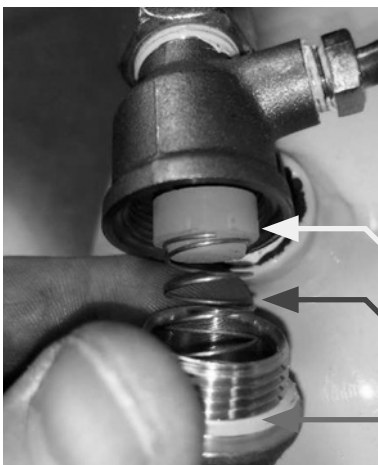

**Figure 3:**

Once the check valve is opened, you should see the spring and plastic plug (blue and yellow arrows). There should be a seal (either white or black on the cap (red arrow)). Carefully remove the cap, spring, and plug. There should be no debris or moisture in this area. The spring may need to be “stretched” a little (maybe ½”) longer than when you take it out. Make sure everything is clean and reassemble.

Yellow

Blue

Red



**YOU MUST  
REGISTER TO  
ACTIVATE  
WARRANTY**



**Scan or go to website hosted below:**

[www.eatoncompressor.com/warranty](http://www.eatoncompressor.com/warranty)

Warranty only valid by following conditions expressed in the Warranty Statement section of this Air Dryer Manual.

## 12. Warranty Statement Refrigerated Air Dryers

WEEMS GLOBAL® (and each of its subsidiaries) makes the following warranties:

***Standard Warranty:*** That each air dryer is free from defects in material, workmanship, and parts for 1 year from the date of delivery. This Standard Warranty includes full 1 year of warranty labor from an authorized technician. Eaton compressor is not responsible for downtime during warranty service. If downtime is necessary, it is at the owner's discretion, obligation, and expense, to have a redundant compressor. Parts shipped for warranty repairs shall only include ground freight charges for the first 90 days of the warranty period, thereafter owner is responsible for all freight charges of parts shipped for for warranty. Any and all express shipping charges of warranty parts would be at the owner's expense.

***\*Standard warranty has no obligation to maintain warranty status, warranty will expire one year from date of delivery. Please see available options below to extend your warranty.***

***Extended Warranty:*** WEEMS GLOBAL will extend your standard 1-year warranty to full 3 years when you opt to register for the extended warranty plan and purchase one Airbase dryer filter replacement kits per year along with following all routine maintenance set forth. Parts shipped for warranty repairs shall only include ground freight charges for the first 90 days of the warranty period, thereafter owner is responsible for all freight charges of parts shipped for warranty. Any and all express shipping charges of warranty parts would be at the owner's expense. Standard technical assistance is provided at no charge during and after the standard warranty period.

***Warranty Shall not apply and WEEMS GLOBAL shall not be responsible nor liable for:***

- Routine service
- Downtime, nor any damages incurred during installation
- Consequential damages such as but not limited to cost of loss of business, product damage, or down time
- Acts of nature, over abuse, malicious destruction, improper maintenance, undersized equipment
- In the case the product has been discontinued at any point the \*Limited lifetime warranty will last five years past the discontinue date. WEEMS GLOBAL has discretion to substitute parts with current model for the five-year duration.
- Deviation from operating instructions or specifications
- Any malfunction caused by failure or improper use and/or maintenance of other components manufactured by others
- Labor charges for repairs or maintenance
- Normal wear and tear parts

***Warranty shall be voided under the following conditions:*** Exposing electrical components to rain or water, or installing the unit in a hostile environment such as acid vapors or any caustic or abrasive matter that may be ingested into the pump, or installing the unit in an enclosed area where lack of cooling ventilation is present, such as in boiler or equipment rooms where the ambient air exceeds 100F.

Further exclusions include failure to fully and completely follow the guidelines set forth in the manual. Of specific note is environments where fine dust is common, such as granite, marble or concrete plants, the compressor MUST be installed in a separate area with its own dedicated ventilation. ***FAILURE TO PROVIDE THIS DUST FREE OPERATING AREA VOIDS THE WARRANTY.***

Parts used for warranty purposes must be supplied by Eaton Compressor. Warranty work should be performed by an Eaton Compressor approved Technician. If any maintenance (other than routine maintenance) is performed by a non-approved Technician, written pre-approval must be obtained from Eaton Compressor, to prevent voiding this warranty. Failure to fully comply with this warranty and fully comply with the manual instructions will void this warranty.

Tech Support: 877.283.7614

effective as of Jan. 2020

*FLEXZILLA and The Flexzilla Stylized X as applied to the body of the air compressor are registered trademarks of Weems Industries, Inc. Silencer™ Patented*