

ELECTRIC OPERATED, OIL-FREE PORTABLE AIR COMPRESSORS

Flexzilla® designs and manufactures products for safe operation. However, operators and maintenance persons are responsible for maintaining safety. All safety precautions are included to provide a guideline for minimizing the possibility of accidents and property damage while equipment is in operation. Keep these instructions for reference.



WARRANTY INFORMATION

DO NOT RETURN TO RETAILER FOR WARRANTY. MUST RETURN TO MANUFACTURER.

CONTACT LEGACY MFG COMPANY
PHONE: 800-645-8258

EMAIL: SERVICE@LEGACYMFG.COM
WEBSITE: WWW.FLEXZILLA.COM

Contents

1. Important Safety Notes - Please read	3-4	5. Troubleshooting.....	7
2. Set Up Instructions.....	5	6. Exploded Diagrams	8-10
2.1 Initial Set Up.....	5	CF10050F.....	8
2.2 Location.....	5	CB20100F / CB20200F.....	9
2.3 Electrical.....	5	7. Pre-Operation Checklist.....	10
3. Operation.....	5-6	8. Location of Product Labels.....	11
3.1 Test Run.....	5	9. Check Valve Maintenance.....	12
3.2 Daily Operation	5-6	10. Warranty	13
4. Maintenance.....	6		
4.1 Cleaning.....	6		
4.2 Cleaning or Changing the Air Filter	6		
4.3 Draining the Air Tank.....	6		
4.4 Pressure Switch	6		
4.5 Testing for Leaks.....	6		



WARRANTY INFORMATION

DO NOT RETURN TO RETAILER FOR WARRANTY. MUST RETURN TO MANUFACTURER.

CONTACT LEGACY MFG COMPANY
PHONE: 800-645-8258

EMAIL: SERVICE@LEGACYMFG.COM
WEBSITE: WWW.FLEXZILLA.COM

1. IMPORTANT SAFETY NOTES

Safety Messages & Signal Words:

⚠ DANGER

Danger indicates an immediate hazardous situation which, if not avoided, will result in death or serious injury.

⚠ WARNING

Warning indicates a potentially hazardous situation which, if not avoided, could result in death or serious injury.

⚠ CAUTION

Caution indicates a potentially hazardous situation which, if not avoided, may result in minor or moderate injury.

NOTICE

Indicates a situation which, if not avoided, may result in damage to product components or other property.

⚠ WARNING

This manual contains important instructions for operating this product. For your safety, and the safety of others, be sure to read this manual thoroughly before operating the product.

Failure to properly follow all the instructions and precautions can cause you and others to be seriously hurt or killed.

⚠ WARNING



EXPLOSION



FIRE

Use caution to minimize risk of fire or explosion.

It is normal for the air compressor motor and pressure switch to produce sparks while operating. If sparks come in contact with vapors from gasoline or solvents, they may ignite and cause a fire or explosion.

Abrasive tools such as grinders, drills and other tools can make sparks that can ignite flammable materials.

Always operate the air compressor a safe distance away from flammable items. Use in well-ventilated areas.

Never exceed the maximum rated pressure.

STORE COMPRESSOR INDOORS

⚠ DANGER

There is a danger of electric shock.

Use only undamaged electrical cords.

DO NOT touch bare wires or receptacles.

DO NOT operate air compressor in wet weather or in wet conditions.

DO NOT touch air compressor or cords if hands or feet are wet. Ensure that all cords are free of damage before connecting to the power supply.

Ensure that you have a sufficient electrical supply for supporting the requirements of the motor.

Improper installation of the grounding plug can result in a risk of electric shock. When repair or replacement of the cord or plug is required, do not connect the grounding wire to either flat terminal. The wire with insulation having an outer surface that is green with or without yellow stripes is the grounding wire.

This product must be grounded. In the event of an electrical short circuit, grounding reduces the risk of electrical shock by providing an escape wire for the electric current.

This product is equipped with a cord having grounding wire and appropriate grounding plug. The plug must be plugged into an outlet that is properly installed and grounded in accordance with the local codes and ordinances.

This product is for use on a nominal 120V circuit and has a grounding plug similar to the plug illustrated in sketch A (below). Only connect the product to an outlet having the same configuration as the plug.

Do not use an adapter with this product.

(SKETCH A)

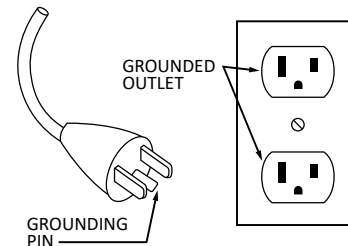

GROUNDING PIN

⚠ CAUTION

Use caution when using extension cords.

Use 3-wire extension cord which is no more than 25' (7,6 m) long, at least 14 gauge, and has a 3-blade grounding plug.

Using an excessively long or thin-wired extension cord will cause severe damage to the motor.

An undersized cord results in a drop in the line voltage and loss of power and overheating.

When in doubt, use a heavier gauge. The smaller the AWG rating, the more current the cord can carry.



WARRANTY INFORMATION

DO NOT RETURN TO RETAILER FOR WARRANTY. MUST RETURN TO MANUFACTURER.

CONTACT LEGACY MFG COMPANY
PHONE: 800-645-8258

EMAIL: SERVICE@LEGACYMFG.COM
WEBSITE: WWW.FLEXZILLA.COM

⚠️ WARNING

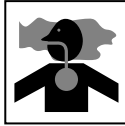

RISK TO BREATHING

Dust or dust-like particulates caused by power-sanding, sawing, grinding, drilling or any other construction-like activities can contain contaminants that are harmful to breathe.

Always use your air compressor in a well-ventilated and clean area.

Never breathe the air that comes directly out of the air compressor or air hose. This air is not suitable for breathing.

Always wear approved safety equipment. When performing dust-creating activities, securely wear properly-fit face masks or respirators.

If you feel ill from breathing while operating your air compressor, stop and seek medical attention immediately.

⚠️ WARNING



FLYING OBJECTS

Flying objects can cause injury to the eyes, head and other parts of the body.

Air-powered equipment and power tools are capable of propelling items (metal chips, fasteners and particulates) at high speed into the air and could result in injury.

Always wear approved head and eye protection.

Never point the air stream at any part of your body, or at another person or animal.

When operating the air compressor, make sure all other people and animals maintain a safe distance.

Do not move the air compressor when the air tank is under pressure.

Never use the air hoses to pull or move the air compressor.

Keep the air compressor on a flat surface.

⚠️ DANGER



RISK OF CUTTING

Moving parts can cause severe trauma.

Keep hands and feet away from rotating parts, tie up long hair, remove jewelry, and DO NOT wear loose clothing.

⚠️ WARNING



BURSTING

Use caution to minimize risk of fire or explosion.

Improper care could lead to the air tank bursting or exploding. Drain air tank daily or after each use to prevent moisture buildup in the air tank.

Rust can weaken the air tank and cause leaks or bursting. If rust is detected, replace tank immediately. Do not try to repair air tank by welding, drilling or modifying it in any other way. These modifications can weaken the air tank and cause a hazardous condition.

If air tank develops a leak, replace air tank immediately. Never repair, weld or make modifications to air tank or its attachments.

Never make adjustments to the factory-set pressures.

Never exceed manufacturer's maximum-allowable pressure rating attachments.

Because of extreme heat, do not use plastic pipe or lead tin solder joints for a discharge line.



WARRANTY INFORMATION

DO NOT RETURN TO RETAILER FOR WARRANTY. MUST RETURN TO MANUFACTURER.

CONTACT LEGACY MFG COMPANY
PHONE: 800-645-8258

EMAIL: SERVICE@LEGACYMFG.COM
WEBSITE: WWW.FLEXZILLA.COM

2. SET UP INSTRUCTIONS

2.1 Initial Set Up

- 1.) Read safety warnings before setting up air compressor.

2.2 Location

- 1.) In order to avoid damaging the air compressor, do not incline the air compressor transversely or longitudinally more than 10°.
- 2.) Place air compressor at least 2 feet away from obstacles that may prevent proper ventilation. Do not place air compressor in an area:
 - a. Where there is evidence of oil or gas leaks.
 - b. Where flammable gas vapors or materials may be present.
 - c. Where air temperatures fall below 32°F or exceed 104°F.
 - d. Where extremely dirty air or water could be drawn into the air compressor.

2.3 Electrical

- 1.) **USE OF AN EXTENSION CORD IS NOT RECOMMENDED** because it could cause the compressor motor to overheat. It's preferable to use additional air hose instead of an extension cord.
- 2.) If use of an extension cord is unavoidable, be sure to use one heavy enough to carry the current your compressor will draw. Minimum cord sizes are as follows:

Ampere Rating Range	Voltage	Length of cord in ft.					
		120V	25 ft.	50 ft.	100 ft.	150 ft.	200 ft.
	240V	50 ft.	100 ft.	200 ft.	300 ft.	400 ft.	500 ft.
8 - 10		18	14	12	10	8	8
10 - 12		16	14	10	8	8	6
12 - 14		16	12	10	8	6	6
14 - 16		16	12	10	8	6	6
16 - 18		14	12	8	8	6	4
18 - 20		14	12	8	6	6	4

- 3.) Use only a 3-wire extension cord that has a 3-blade grounding plug and a 3-slot receptacle that will accept the plug of the compressor.
- 4.) Examine cords before using. Do not use the compressor if its cord is damaged. Do not use a damaged extension cord.
- 5.) Keep cords away from heat and sharp edges. Do not pull on a cord to disconnect a plug – grasp the plug.

- 6.) Always shut off the compressor pressure switch before unplugging the compressor.

3. OPERATION

3.1 Test Run

Before using the air compressor for the first time complete a test run as follows:

- 1.) Turn the power switch to the OFF position. Plug the power supply cord into a power supply socket. Start the air compressor by turning the power switch to the ON position. The pressure gauge reading will slowly rise as pressure increases inside the air tank. When the gauge reading reaches 120 PSI – 125 PSI, the pressure switch will automatically turn the power off. This indicates the compressor is working normally.
- 2.) Turn the power switch to the OFF position, unplug the power supply cord and release the air in the tank by pulling on the safety valve. At this point proceed to the next step.

Note: If the air compressor is not working properly, the pressure gauge will indicate that there is a decrease in pressure in the air tank. If there is an air leak from the compressor the pressure in the air tank decreases, the pressure switch resets and the motor automatically turns back on.

If you detect an air leakage, turn the power switch to the OFF position, release the air from the tank by pulling on the safety valve. Unplug the power supply cord and contact Customer Support for assistance.

3.2 Daily Operation

Starting the compressor:

- 1.) Turn the power switch to the OFF position.
- 2.) Attach air hose to the 1/4" Universal/Industrial Quick Connector.
- 3.) Check that all air fittings are tight and close manual drain valve.
- 4.) Maintain 2 feet of open space around the air compressor.
- 5.) Plug the power supply cord into a 110V 20 amp outlet/breaker.
- 6.) Turn the power switch to the ON position.
- 7.) Let the motor run and tank fill until motor turns off.



DO NOT RETURN TO RETAILER FOR WARRANTY. MUST RETURN TO MANUFACTURER.
 CONTACT LEGACY MFG COMPANY EMAIL: SERVICE@LEGACYMFG.COM
 PHONE: 800-645-8258 WEBSITE: WWW.FLEXZILLA.COM

- 8.) To regulate air flow. While the air compressor is running, turn on your tool and turn the regulator knob to the right increasing the pressure. Turn the pressure up until the desired pressure is reached.
- 9.) Operate air tool normally. Do not use continuously (running) for more than (8-12) hours.

Shutting down the compressor:

- 1.) Turn the power switch to the OFF position.
- 2.) Disconnect the power cord from the power supply and wrap the power cord around the air compressor handle to reduce the risk of damage.
- 3.) Release all the pressure and moisture from the air tank by manually opening the drain valve.
- 4.) Clean the air compressor to remove all dirt and dust.

Before storing for a prolonged period of time:

- 5.) Cover the air compressor to protect the unit from dust and moisture.
- 6.) Do not stack or store any items on top of or around the air compressor. Damage could occur.

4. MAINTENANCE

4.1 Cleaning

Clean items with a soft brush, or wipe with a moistened cloth using a biodegradable solvent.

Do not use flammable liquids such as gasoline or alcohol. Always keep parts clean from dirt and dust for better performance.

4.2 Cleaning or Changing the Air Filter

The air filter is designed to reduce noise and help prevent particulates in the air from entering and damaging the air compressor.

After being used for a period of time, the air filter will become clogged. This will reduce the air intake capabilities of the air compressor, reducing performance. Therefore, the air filter must be cleaned or replaced regularly.

- 1.) Open the lid on the air filter, then remove the air filter element.
- 2.) To clean the element, blow off or brush off the dirt and dust.
- 3.) If clogged, replace with a new air filter.

4.3 Draining the Air Tank

The frequency at which you should drain the air tank depends on the environmental conditions and the amount of operation time logged. The average draining frequency is every 1 to 2 days.

- 1.) Place the air compressor above a container capable of holding water.
- 2.) With compressed air in the air tank, slowly turn the drain valve knob to the forward (open) or straight position. The water in the air tank will drain out.
- 3.) After all of the accumulated water has drained out, turn the drain valve knob to the closed or left position in order to avoid leakage.
- 4.) Draining the air tank protects parts from rust and corrosion.

4.4 Pressure Switch

The pressure switch is factory pre-set to shut off at between 120-125 PSI and restart at between 90-95 PSI.

4.5 Testing for Leaks

Make sure all connections are tight. Do not overtighten.

A small leak in any hose or pipe connection will reduce the air compressor's performance.

To test for small leaks, spray a small amount of soapy water on the area suspected of leaking. If the soap bubbles, replace the broken part.



**WARRANTY
INFORMATION**

DO NOT RETURN TO RETAILER FOR WARRANTY. MUST RETURN TO MANUFACTURER.

CONTACT LEGACY MFG COMPANY
PHONE: 800-645-8258

EMAIL: SERVICE@LEGACYMFG.COM
WEBSITE: WWW.FLEXZILLA.COM

5. TROUBLESHOOTING

Problem	Possible Cause	Repair
Pressure drop in the tank.	Air leaks at connections.	Let the compressor build pressure in the tank, to the maximum pressure if possible. Brush soapy water on air connections and look carefully for air bubbles. Tighten leaky connections. If the problem persists, contact Customer Support for further advice.
The unloader valve leaks when the compressor is idle.	Unloader valve seal is defective.	Let the air in the air tank flow out until all the pressure is released. Then remove the unloader valve plug and clean the valve seal. If necessary, replace the seal and then reinstall all components.
The compressor stopped and does not start.	The thermal protection turned on because the motor is overheating.	Check that the main voltage corresponds to the air compressor specifications. An extension cord that is too thin or too long can cause a voltage drop and cause the motor to overheat. Excessive use (over 1 hour continuous use) can cause the motor to overheat. Allow the motor to cool down.
	Motor windings are burned out.	Contact Customer Support.
The motor does not start and makes a humming noise.	Capacitor is burned out.	Contact Customer Support.
The motor does not start or starts slowly.	Low voltage supply to the motor.	Check that the main voltage corresponds to the air compressor specifications. An extension cord that is too thin or too long can cause a voltage drop. Use heavy duty extension cords. Ensure that the air compressor is plugged into a fully functional power outlet.
The compressor is noisy with metallic clangs.	Compressor head gasket or reed valve is damaged.	Stop the compressor and contact Customer Support.
The compressor does not reach the maximum pressure.	Compressor head gasket or reed valve is damaged.	Stop the compressor and contact Customer Support.
The compressor doesn't seem to provide as much air as it did when new and/or the compressor cuts off within a much shorter time period.	The pressure switch needs adjusting.	Stop the compressor and contact Customer Support.
	The tank is full of water due to condensation.	Open the drain valve and release the water from the tank.
The motor pump unit does not stop when the tank pressure reaches its maximum working pressure.	Pressure switch is defective or needs adjusting.	Stop the compressor immediately and contact Customer Support.

6. EXPLODED DIAGRAMS

CF10050F

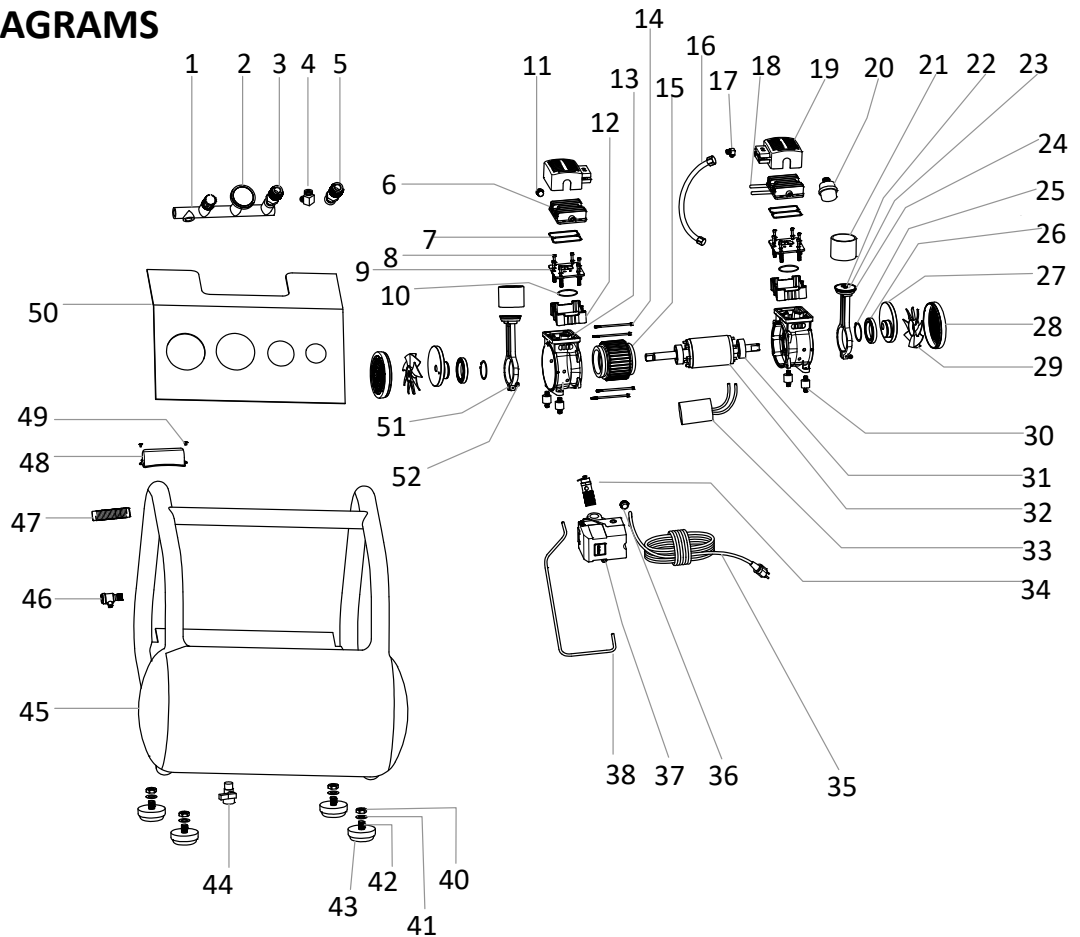

#	PART NO./KIT CODE	DESCRIPTION	QTY.	#	PART NO./KIT CODE	DESCRIPTION	QTY.	#	PART NO./KIT CODE	DESCRIPTION	QTY.
1	RP000500	REGULATOR SUPPORT	1	19	RP000507 or A	CYLINDER HEAD COVER	2	37	RP000512	PRESSURE SWITCH	1
2	RP000501	REGULATOR PRESSURE GAUGE	1	20	RP000508 or A	AIR FILTER	2	38	RP000513	RELEASE TUBE	1
3	A77425	QUICK COUPLER	1	21	A or B	CYLINDER	2	39	RP000514	AIR DELIVERY TUBE	1
4	RP000502	ELBOW	1	22	A or B	SCREW	2	40	D	NUT	4
5	A77425	QUICK COUPLER	1	23	A	PRESS PAD	2	41	D	SPRING	4
6	RP000503 or A	CYLINDER HEAD	2	24	A or B	TEFLON PISTON CUP	2	42	D	SCREW	4
7	A or B	RUBBER SEAL	2	25	A	CIRCLIP	2	43	D	RUBBER FOOT	4
8	A or B	SCREW	8	26	A	BEARING	2	44	RP000515	WATER DRAIN	1
9	A or B	VALVE PLATE	2	27	A	CRANKSHAFT	2	45	RP000516	TANK	1
10	A or B	RUBBER SEAL	2	28	A or C	FAN	2	46	RP000517	CHECK VALVE	1
11	A	PLUG	1	29	A or C	FAN COVER	2	47	RP000518	RUBBER GRIP	1
12	A	CYLINDER SUPPORT	2	30	RP000509	INSULATOR	4	48	E	CAPACITOR COVER	1
13	A	CRANKCASE	2	31	A	BEARING	2	49	E	SCREW	1
14	A	SCREW	4	32	A	ROTOR	1	50	RP000519	PANEL	1
15	A	STATOR & WINDING	1	33	RP000510	CAPACITOR	1	51	A	CONNECTING ROD	2
16	RP000504	AIR DELIVERY TUBE	1	34	RP000511	SAFETY VALVE	1	52	A	SCREW	4
17	RP000505	ELBOW	1	35	F	POWER CORD	1				
18	RP000506 or A	CYLINDER HEAD CONNECTION	2	36	F	CABLE LOCK	1				

KIT CODE	PART NO.	DESCRIPTION
A	RP000540	Flexzilla® Portable Air Compressors Replacement Pump and Motor for CF10050F
B	RP000541	Flexzilla® Portable Air Compressors Pump Repair Kit for CF10050F
C	RP000542	Flexzilla® Portable Air Compressors Replacement Fan and Cover for CF10050F
D	RP000545	Flexzilla® Portable Air Compressors Replacement Foot Kit for CF10050F
E	RP000543	Flexzilla® Portable Air Compressors Replacement Capacitor Cover for CF10050F
F	RP000544	Flexzilla® Portable Air Compressors Replacement Power Cord for CF10050F

6. EXPLODED DIAGRAMS

CB20100F/CB20200F

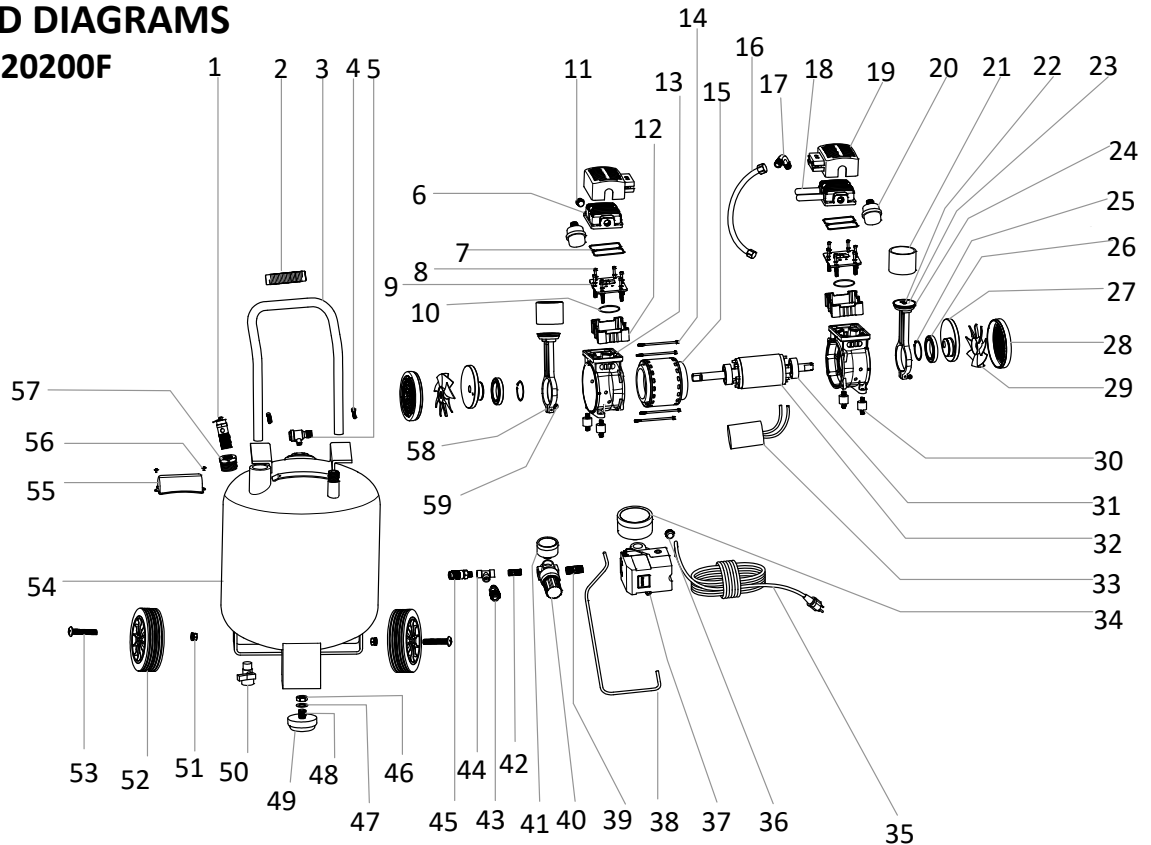

#	PART NO./KIT CODE	DESCRIPTION	QTY.	#	PART NO./KIT CODE	DESCRIPTION	QTY.	#	PART NO./KIT CODE	DESCRIPTION	QTY.
1	RP000600	SAFETY VALVE	1	21	A or B	CYLINDER	2	41	RP000618	REGULATOR PRESSURE GAUGE	1
2	RP000601	RUBBER GRIP	1	22	A or B	SCREW	2	42	RP000619	CONNECTOR	1
3	RP000602	HANDLE	1	23	A	PRESS PAD	2	43	A77425	QUICK COUPLER	1
4	RP000603	SCREW	2	24	A or B	TEFLON PISTON CUP	2	44	RP000620	THREE WAY ELBOW	1
5	RP000604	CHECK VALVE	1	25	A	CIRCLIP	2	45	A77425	QUICK COUPLER	1
6	RP000605 or A	CYLINDER HEAD	2	26	A	BEARING	2	46	D	NUT	2
7	A or B	RUBBER SEAL	2	27	A	CRANKSHAFT	2	47	D	SPRING	2
8	A or B	SCREW	8	28	A or C	FAN	2	48	D	SCREW	2
9	A or B	VALVE PLATE	2	29	A or C	FAN COVER	2	49	D	RUBBER FOOT	2
10	A or B	RUBBER SEAL	2	30	RP000611	INSULATOR	4	50	RP000621	DRAIN VALVE	1
11	A	PLUG	1	31	A	BEARING	2	51	E	NUT	2
12	A	CYLINDER SUPPORT	2	32	A	ROTOR	1	52	E	WHEEL	2
13	A	CRANKCASE	2	33	RP000612	CAPACITOR	1	53	E	SCREW	2
14	A	SCREW	4	34	RP000613	TANK PRESSURE GAUGE	1	54	RP000625	10 GAL TANK (CB20100F)	1
15	A	STATOR & WINDING	1	35	G	POWER CORD	1	54	RP000626	20 GAL TANK (CB20200F)	1
16	RP000606	AIR DELIVERY TUBE	1	36	G	CABLE LOCK	1	55	F	CAPACITOR COVER	1
17	RP000607	ELBOW	1	37	RP000614	PRESSURE SWITCH	1	56	F	SCREW	1
18	RP000608 or A	CYLINDER HEAD CONNECTION	2	38	RP000615	RELEASE TUBE	1	57	RP000622	THREAD ADAPTOR	1
19	RP000609 or A	CYLINDER HEAD COVER	2	39	RP000616	CONNECTOR	1	58	A	CONNECTING ROD	2
20	RP000610 or A	AIR FILTER	2	40	RP000617	REGULATOR	1	59	A	SCREW	4

KIT CODE	PART NO.	DESCRIPTION
A	RP000640	Flexzilla® Portable Air Compressors Replacement Pump and Motor for CB20100F and CB20200F
B	RP000641	Flexzilla® Portable Air Compressors Pump Repair Kit for CB20100F and CB20200F
C	RP000642	Flexzilla® Portable Air Compressors Replacement Fan and Cover for CB20100F and CB20200F
D	RP000645	Flexzilla® Portable Air Compressors Replacement Foot Kit for CB20100F and CB20200F
E	RP000646	Flexzilla® Portable Air Compressors Replacement Wheel Kit for CB20100F and CB20200F
F	RP000643	Flexzilla® Portable Air Compressors Replacement Capacitor Cover for CB20100F and CB20200F
G	RP000644	Flexzilla® Portable Air Compressors Replacement Power Cord for CB20100F and CB20200F

7. PRE-OPERATION CHECKLIST

Initial Set-up:

Package Contents:

- 1.) Air compressor
- 2.) Owner's Manual
- 3.) Air Filter Kit (2)
 - Includes pre-assembled unit consisting of male housing, female housing, filter element, and intake tube
- 4.) Anti-Vibration Foot Kit (4)
 - Includes elastomer pad, screw, and nut
- 5.) Wheel Kit (2)
 - Includes wheel, bolt, flat washer, lock washer, and nut
- 5.) Hot Surface Protection Kit (2)
 - Includes plastic head cover, head cover clamp, 2 screws

Assembly:

1.) Install Foot Kit (2 Locations)

- Lay down compressor handle side down to prevent unit from rolling
- Insert bolt through elastomer foot and through hole located in frame
- Thread nut onto bolt, lightly tighten
- Repeat at remaining location
- Leave compressor in this position for step 2

2.) Install Wheel Kit (2 Locations) (CB20100F/CB20200F models only)

- Lift compressor slightly to raise wheel off ground
- Insert bolt through wheel and through hole in bracket
- Install flat washer over bolt
- Install lock washer over bolt
- Thread nut onto bolt and tighten with wrench
- Repeat at remaining position
- Tip compressor upright by using the handle

3.) Install Air Filter

CF10050F (1 Location)

- When facing the front of compressor, locate the thread port in motor head along left side
- Thread filter into port, and tighten by hand securely

CB20100F/CB20200F (2 Locations)

- When facing the back of compressor, locate the thread ports near the top of the motor head behind the handle
- Thread filter into port, and tighten by hand securely

4.) Install Hot Surface Protection Kit (2 Locations)

- When facing the rear of the compressor, place plastic head cover over the cylinder head
 - *Note: The screw holes are located near the center of the compressor pump*
- Place head cover clamp below the plastic head cover
- Insert the 2 screws and tighten with PH2 screw driver securely

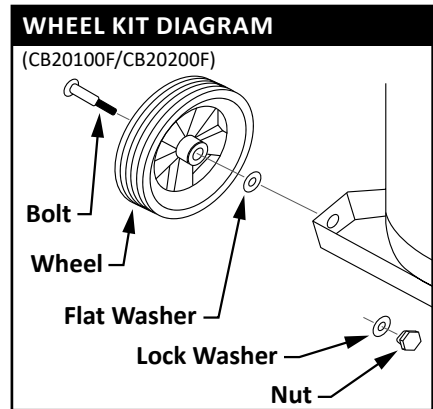
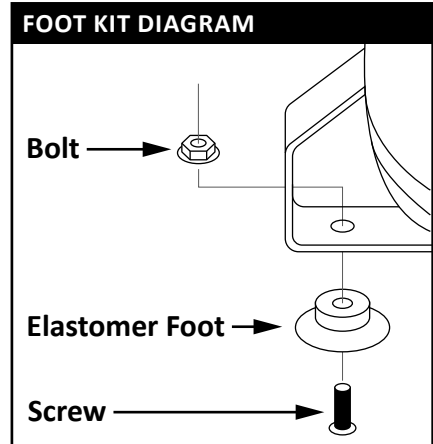

DO NOT RETURN TO RETAILER FOR WARRANTY. MUST RETURN TO MANUFACTURER.

CONTACT LEGACY MFG COMPANY
PHONE: 800-645-8258

EMAIL: SERVICE@LEGACYMFG.COM
WEBSITE: WWW.FLEXZILLA.COM

8. LOCATION OF PRODUCT LABELS

Read these important labels before operating.

These labels provide important safety and maintenance information. These labels should be considered as permanent parts of the air compressor. Should any of these labels become illegible, damaged or removed, please contact Legacy Manufacturing Company Service department for replacements by phone at 800-645-8258 ext. 121 or email service@legacymfg.com, M-F 8am-5pm CST.

CF10050F:

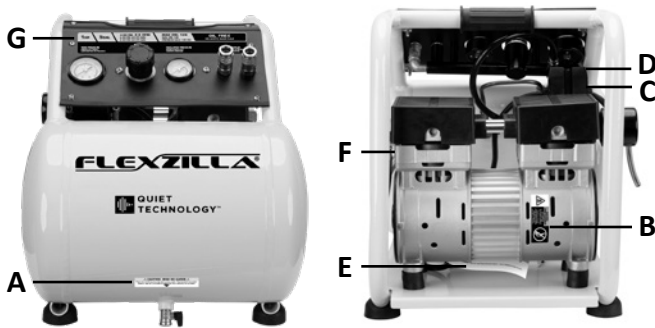

CB20100F / CB20200F:

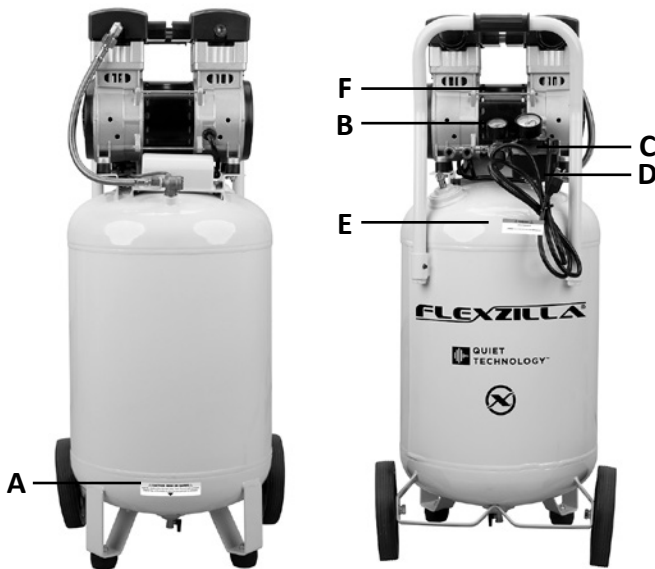

PRODUCT LABEL	
A	<p>CAUTION / PRECAUCIÓN / ATTENTION</p> <p>Drain the moisture from the tank every week. Prevent tank corrosion. Drene la humedad del tanque cada semana. Evite la corrosión del tanque. Purger l'humidité du réservoir chaque semaine. Prévenir la corrosion du réservoir.</p>
B	<p>WARNING / ADVERTENCIA / AVERTISSEMENT</p> <p>HOT SURFACE Do not touch. Allow to cool before servicing. SUPERFICIE CALIENTE No tocar. Dejar enfriar antes de dar servicio. SURFACE CHAUDE Ne pas toucher. Laisser refroidir avant toute intervention.</p>
C	<p>POWER SWITCH INTERRUPTOR DE ENCENDIDO INTERRUPTEUR D'ALIMENTATION</p> <p>Auto/On Auto/Encendido Auto/Marche</p> <p>Off Apagado Arrêt</p>
D	<p>WARNING / ADVERTENCIA / AVERTISSEMENT</p> <p>RISK OF BURSTING: Do not adjust factory settings RIESGO DE EXPLOSION: No ajuste la configuración de fábrica RISQUE D'ÉCLATEMENT: Ne pas changer les réglages d'usine</p> <p>RISK OF ELECTRIC SHOCK: Do not remove cover RIESGO DE SHOCK ELÉCTRICO: No retire la cubierta RISQUE DE CHOC ÉLECTRIQUE: Ne retirez pas le couvercle</p>
E	<p>ADVERTENCIA Proposition 65 de California AVERTISSEMENT Rango de operar y de fabricación AVERTISSEMENT Rango de operar y de fabricación www.P65Warnings.ca.gov</p> <p>ADVERTENCIA Proposition de California 65 AVERTISSEMENT Cancele el traslado de / l'appareil reproducteur www.P65Warnings.ca.gov</p> <p>WARNING Cancer and Reproductive Harm - www.P65Warnings.ca.gov</p>
F	<p>FLEXZILLA®</p> <p>Air Compressor Model: / Modelo: / Modèle: ##### Compresor de aire Compresseur d'air</p> <p>Voltage & Current 115V ~ 60 Hz #A Voltaje y corriente / Tension et intensité</p> <p>Power # HP / # CV Alimentación / Puissance</p> <p>Tank / Tanque / Réservoir # gal. (# L)</p> <p>No-load speed 1750 rpm / tr/min Velocidad sin carga / Vitesse à vide</p> <p>Max air pressure 125 psi / lb/po² Presión máx. de aire / Pression d'air max</p> <p>Serial No. N.º de serie / N.º de série</p> <p>Made in China / Hecho en China / Fabriqué en Chine</p> <p>WARNING / ADVERTENCIA / AVERTISSEMENT</p> <p>To reduce the risk of injury, user must read and understand instruction manual. Para reducir el riesgo de lesiones, el usuario debe leer y comprender el instructivo. Pour réduire le risque de blessure, l'utilisateur doit lire et comprendre le manuel d'instruction.</p>
G	<p>1HP 5GAL 80 PSI: 2.5 CFM MAX PSI: 125 OIL FREE A 90 PSI: 2.5 CFM MAX. PSI: 125 SIN ACEITE / SANS HUILE A 90 PSI: 2.5 CFM PRESSION MAX: 125 PSI</p> <p>TANK PRESSURE / PRESIÓN DE TANQUE / PRESSION RÉSERVOIR</p> <p>REGULATOR / REGULADOR / RÉGULATEUR</p> <p>REGULATED PRESSURE / PRESIÓN REGULADA / PRESSION RÉGULÉE</p> <p>QUICK COUPLER / ACCESORIO DE BARRA / COUPLER RAPIDE</p>

9. CHECK VALVE MAINTENANCE (CB20100F / CB20200F MODELS)



Figure 1:

The check valve is an integral piece to the compressor being able to pump and hold air. It is located on the back of the tank. Prior to any maintenance on the system the air must be fully released. This can be done by opening the over pressure relief valve or using an air gun to drain the tank.



Figure 2:

There is a removable cap on the check valve. This should be easily removed with a wrench. CAUTION: There is a spring inside this cap. It is not a strong spring but could spring out and be lost if you are not careful.

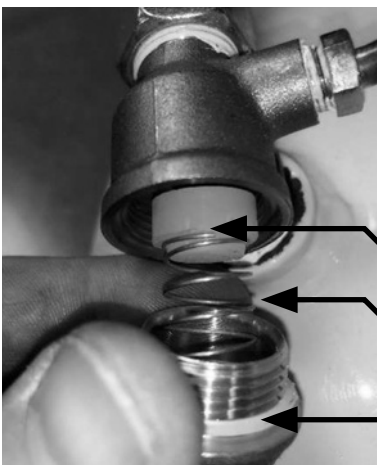

Figure 3:

Once the check valve is opened, you should see the spring and plastic plug (blue and yellow arrows). There should be a seal (either white or black on the cap (red arrow)). Carefully remove the cap, spring, and plug. There should be no debris or moisture in this area. The spring may need to be "stretched" a little (maybe 1/2") longer than when you take it out. Make sure everything is clean and reassemble.

Yellow

Blue

Red



**WARRANTY
INFORMATION**

DO NOT RETURN TO RETAILER FOR WARRANTY. MUST RETURN TO MANUFACTURER.

CONTACT LEGACY MFG COMPANY
PHONE: 800-645-8258

EMAIL: SERVICE@LEGACYMFG.COM
WEBSITE: WWW.FLEXZILLA.COM

10. Warranty Statement

LIMITED WARRANTY STATEMENT

LEGACY MANUFACTURING COMPANY ("LEGACY") warrants that its products will be free from defects in material and workmanship under normal use for the period listed below:

Flexzilla® Portable Air Compressors 2 years from date of purchase

LEGACY'S sole obligation under this warranty is limited to replacing, free of charge, any equipment or parts proven by an authorized service center to be defective in material or workmanship under normal use during the applicable warranty time period. To obtain repair or replacement, the product must be shipped to a LEGACY authorized Warranty and Service Center during the warranty period, transportation charges prepaid by the customer, with proof of date of purchase and explanation of the alleged defect. In the event of repair or replacement, the warranty period shall not be extended beyond the original warranty period.

This warranty is extended to the original purchaser only and is not transferable. This warranty does not apply to normal wear items such as packings, seals, tips and filters; equipment damaged from accident, overload, abuse, misuse, negligence, improper setup or installation, abrasive or corrosive materials; equipment repaired or altered by anyone not authorized by LEGACY to repair and alter equipment, or by acts of God. No allowance will be granted for any repairs or alterations made by a purchaser without LEGACY'S prior written consent.

LEGACY WILL BEAR NO OTHER EXPENSE, INCLUDING BUT NOT LIMITED TO LABOR AND MATERIAL COSTS (OTHER THAN THOSE SPECIFIED HEREIN) OF ANY KIND, AND YOUR EXCLUSIVE REMEDY, IN LIEU OF ALL INCIDENTAL, SPECIAL, CONSEQUENTIAL OR ANY OTHER DAMAGES, INCLUDING, BUT NOT LIMITED TO, DAMAGES FOR NEGLIGENCE, IS LIMITED TO REPAIR OR REPLACEMENT AS HERETOFORE DESCRIBED. THE FOREGOING WARRANTIES ARE IN LIEU OF ALL OTHER REPRESENTATIONS OR WARRANTIES, EXPRESS OR IMPLIED OF ANY KIND REGARDING ANY EQUIPMENT, INCLUDING BUT NOT LIMITED TO THE IMPLIED WARRANTIES OF MERCHANTABILITY AND FITNESS FOR A PARTICULAR PURPOSE OR USE. IN NO CASE SHALL LEGACY BE LIABLE FOR DEATH, INJURIES TO PERSON OR PROPERTY OR FOR INCIDENTAL, SPECIAL OR CONSEQUENTIAL DAMAGES ARISING FROM THE USE OF OUR PRODUCTS, WHETHER BASED UPON BREACH OF WARRANTY, BREACH OF CONTRACT, NEGLIGENCE, STRICT LIABILITY, OR ANY OTHER LEGAL THEORY.

Unless modified in writing, and signed by both parties, this Limited Warranty is understood to be the complete and exclusive agreement between the parties, superseding all prior agreements, oral or written, and all other communications between the parties relating to the subject matter of this Limited Warranty. Any action for breach of warranty must be commenced within twelve (12) months following the end of the warranty period.

While necessary maintenance or repairs on your Legacy equipment can be performed by any company, we recommend that you use only authorized Legacy dealers. Improper or incorrectly performed maintenance or repair voids this warranty.

Contact Legacy Manufacturing Co.: 800-645-8258
Email service@legacymfg.com or visit www.flexzilla.com

FLEXZILLA and The Flexzilla Stylized X as applied to the body of the air compressor are registered trademarks of Weems Industries, Inc.

 WARRANTY INFORMATION	DO NOT RETURN TO RETAILER FOR WARRANTY. MUST RETURN TO MANUFACTURER.	
	CONTACT LEGACY MFG COMPANY PHONE: 800-645-8258	EMAIL: SERVICE@LEGACYMFG.COM WEBSITE: WWW.FLEXZILLA.COM